

**Evolve® - Roller Blind for Windows by Umbra**  
in Blindspace® C130x155

HEAD BOX C130x155SS

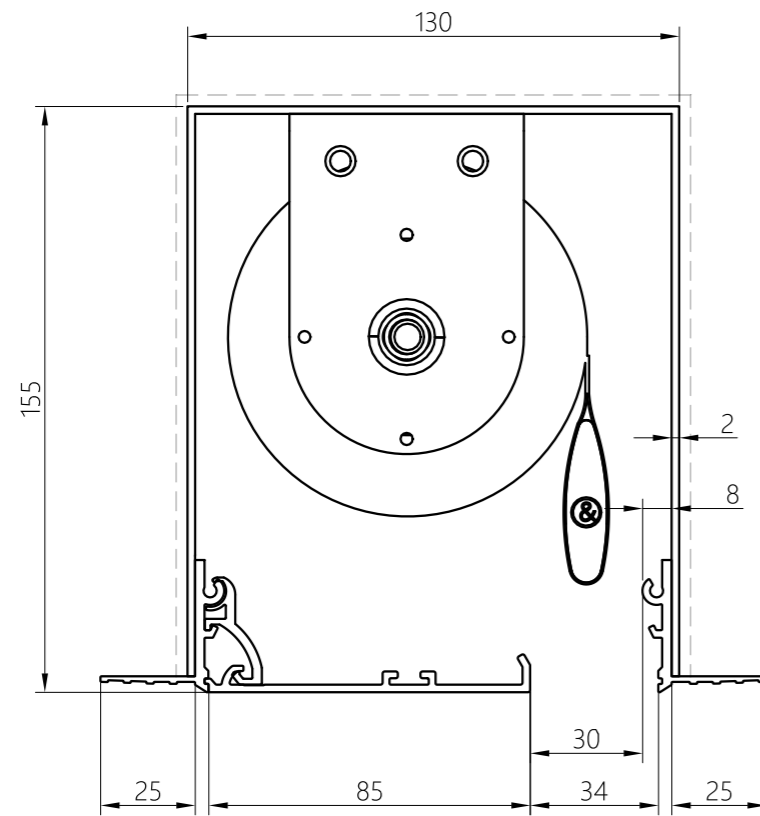

1:2 scale

PRODUCT REFERENCE

**C130x155SS**  
SERIES SIZE CORNERS

CONCEALMENT CONFIGURATION



Head Box

FRONT CORNERS VARIATIONS

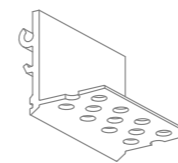

P- Perforated Flange

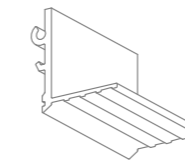

S- Skim Coat Flange

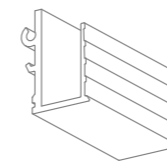

U- Uprand Flange

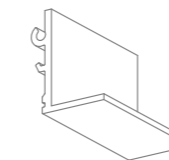

V- Visible Flange

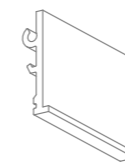

N- No Flange



COVER HINGE  
to hold cover plate,  
installed on either side

Product	Umbra solution for blinds in dedicated concealed Blindspace® boxes
Description	Recessed roller blind application concealed in dedicated box with hinged cover flush with wall or ceiling finished surface.
Blind sizes	Please see size chart and supplier details for blind sizes such as max. width, height and area.
Finishes	Provided in RAL 9016 (white) Optional powder coating to other RAL colours available.
Material	Powder Coated Aluminium, Back Box EN AW-1050A, Front Corners and Cover EN 6063 T6
Optional accessories	End cap Splice pin (to align boxes) Splice plate (to align covers) Chain guide (for manual blinds) Covers in various widths
Box length	3000mm Cut to size for shorter lengths. Spliced together for longer lengths.
Installation	Boxes to be fixed with countersunk screws every 200mm through back (and both flanges when available) into appropriate backing. Scrim tape to be used on flanges. Finished plaster level to be flush with cover. Allow 3mm recess space for ease of installation, shown in dash line around boxes
Print date	2023/12/21
Page size	ISO A3 420x297

