

UMBRA®

Fitting Instructions

KuroLok RL

Zipped edge rooflight blind

Thank you for choosing KuroLok RL

Please unpack the delivery and check you have:

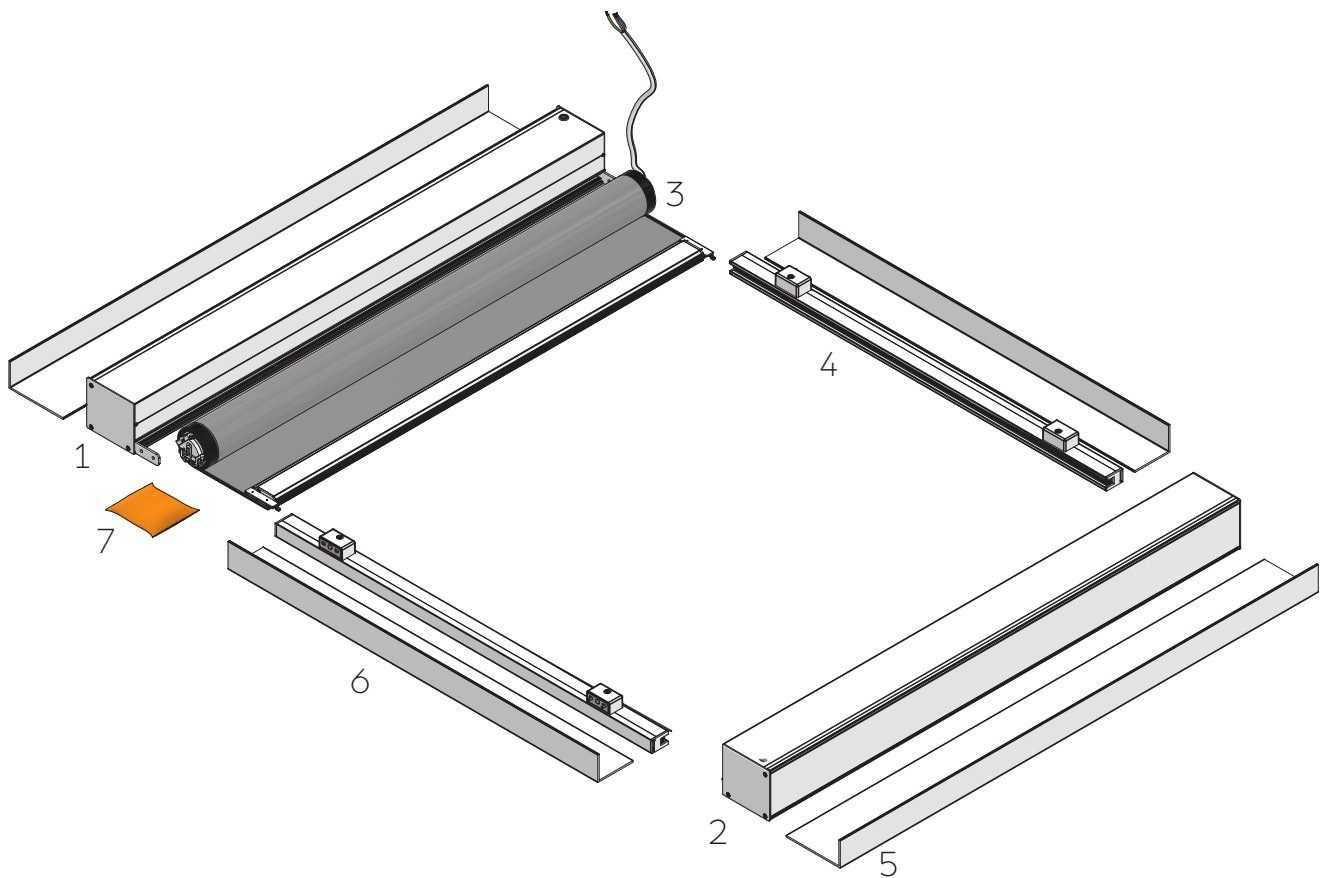

1. 1x fabric cassette
2. 1x tension cassette
3. 1x roller blind (may already be in installed fabric cassette)
4. 2x side channels
5. 2x 115mm shelving
6. 2x 75mm shelving
7. 1x orange bag containing components & fixing screws

**PLEASE NOTE:** This installation requires at least 2 persons

## IMPORTANT

- Installation instructions must be followed otherwise the warranty will be void.
- It is the duty of the installer to pass on user and maintenance instructions to the end user. The installer must also demonstrate the blind is fully working in their handover to the end user.
- Motorised blinds must be connected to an RCD protected circuit. Always consult a qualified electrician regarding any electrical installation
- It is the installer's responsibility to ensure that suitable fixings are used to secure the blind in place
- It is the installer's responsibility to ensure safety is always maintained. A full risk assessment must be carried out and documented prior to installation.

## BEFORE INSTALLATION

- For best results, this product should only be installed by a trained installation team
- If you are unsure of any element of the install, please contact your supplier before proceeding
- All components should be checked for damage. Damaged components should be reported to your supplier prior to the installation beginning.

To view the fitting video for KuroLok RL, please scan the QR code below.



## TENSION UNIT WARNING – please read before proceeding

This blind contains constant tension spring (CTS) units.

Take great care when pulling the cord out of the tension unit! These are powerful units and can cause damage or injury if misused!

Under NO circumstances must the cord be released to wind back into the tension unit unchecked. If this happens it WILL result in damage to the CTS and MAY ALSO result in injury or damage to persons or property.

For your convenience and safety every tension unit is provided with a locking point, which is marked with an arrow. Pull the cord to rotate the spool inside the tension unit until you see the hole in the spool line up with the locking point. Insert a pin\* through the locking point into the spool to lock the tension unit.

\*for a locking pin you may use any metal shaft of 3–4mm diameter, e.g. small screwdriver or screw. Ensure this does not fall inside the tension unit.

To remove the locking pin, pull the cord tight to take the tension off the pin, lift the pin out and allow any slack cord to SLOWLY feed back into the tension unit.

In some cases your blind will be delivered with the tension unit already locked with a screw inserted into the locking point. DO NOT USE A SCREWDRIVER TO REMOVE THIS SCREW, but remove it following the instructions above.

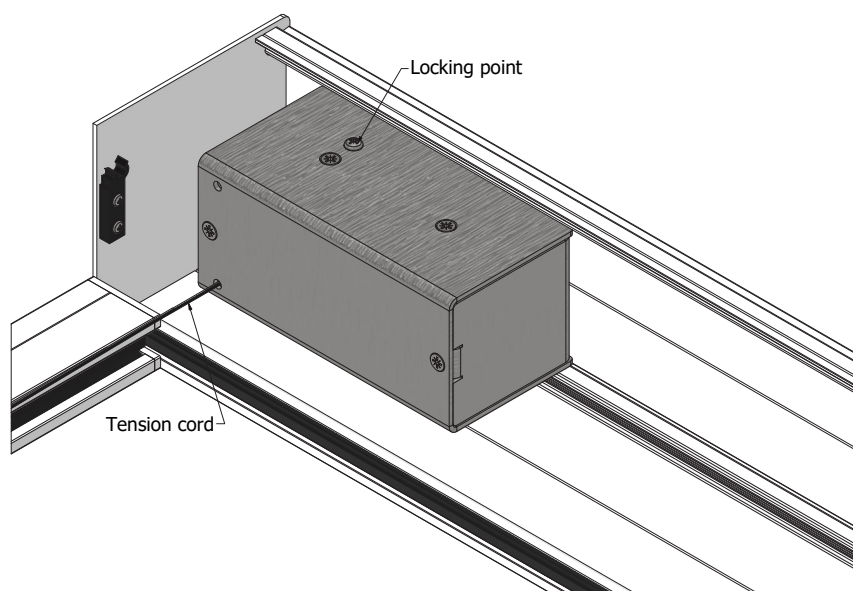

## FITTING OPTIONS NOTE

There are many ways to fit a KuroLok RL. In this manual we cover horizontal installation of STANDARD ORIENTATION on top of L-shaped fixing shelf. This is the most common fixing scenario.

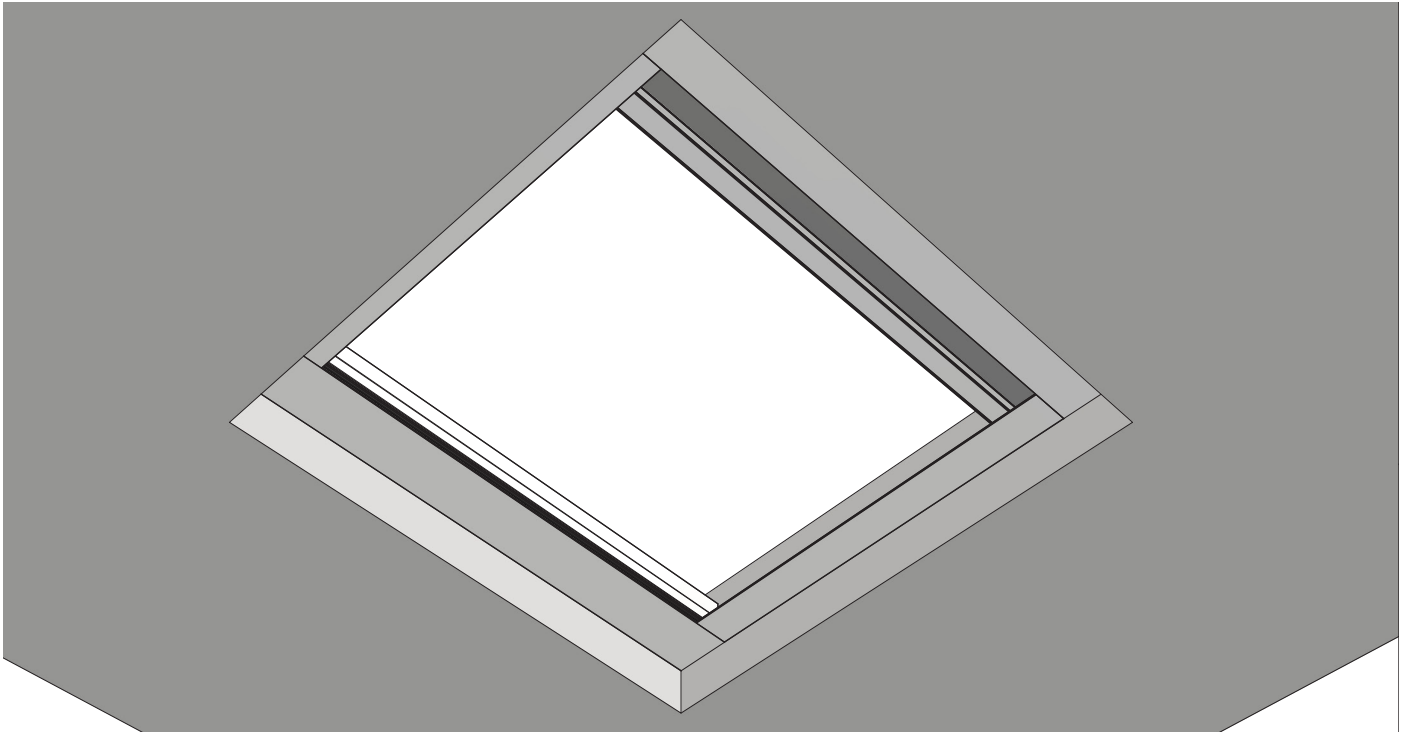

RECOMMENDED METHOD: Standard orientation with shelving, as covered in this manual.

PLEASE NOTE: the adjustable side channel fixing brackets DO NOT support the weight of the blind and must ONLY be used when the blind is installed on a shelf. If the blind is not being installed on a shelf you MUST fix directly through the side channels using fixings sufficient to take the weight of the blind.

Other possible fixing options are shown below but should only be considered by installers who have received appropriate training.

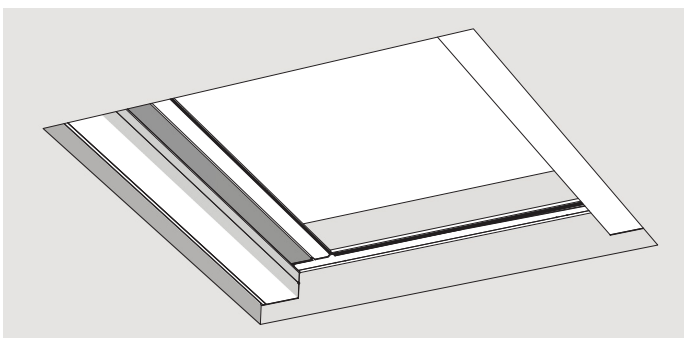

Reverse orientation, reveal fixed

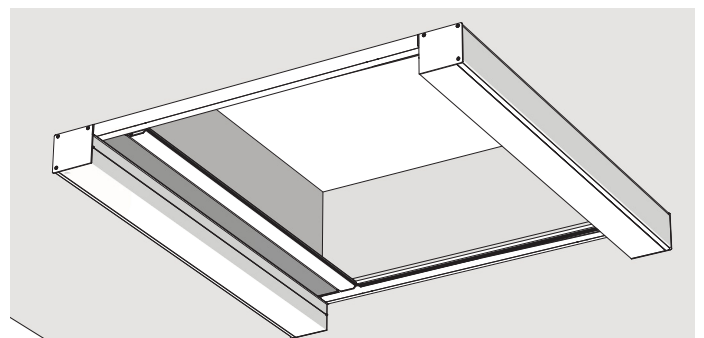

Reverse orientation, face fixed

## STEP 1

Preparing your blind.

**PLEASE NOTE:** if your blind is already in the headbox, go to step 2B

Remove the screw from each end of the cassette (both ends of the blind). Keep these screws (x4) in a safe place until the end of the installation.

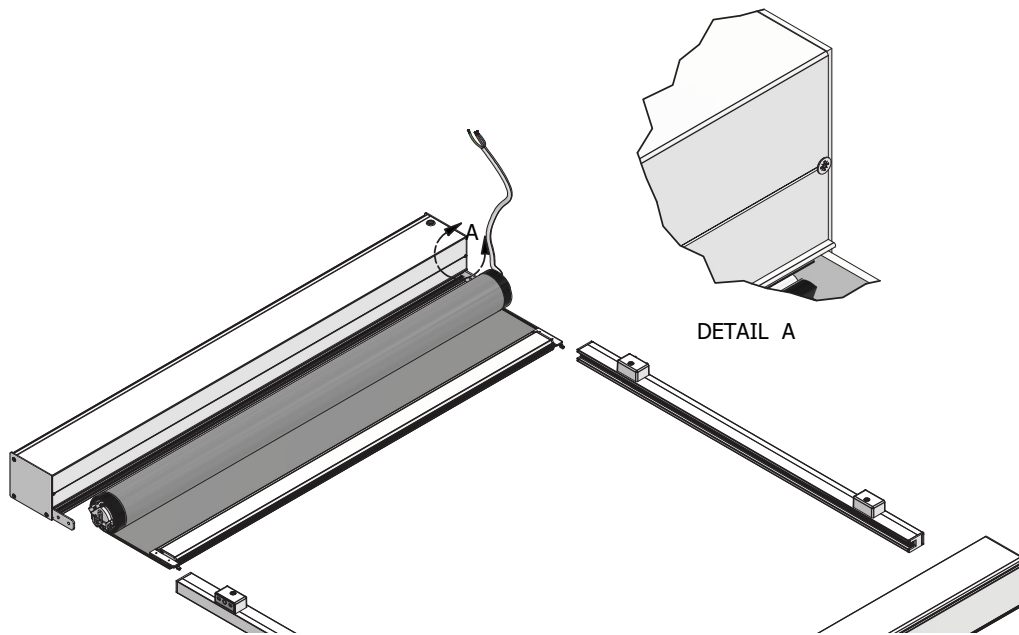

Remove both front covers by hinging them up by approx. 8mm and sliding back slightly to release them.

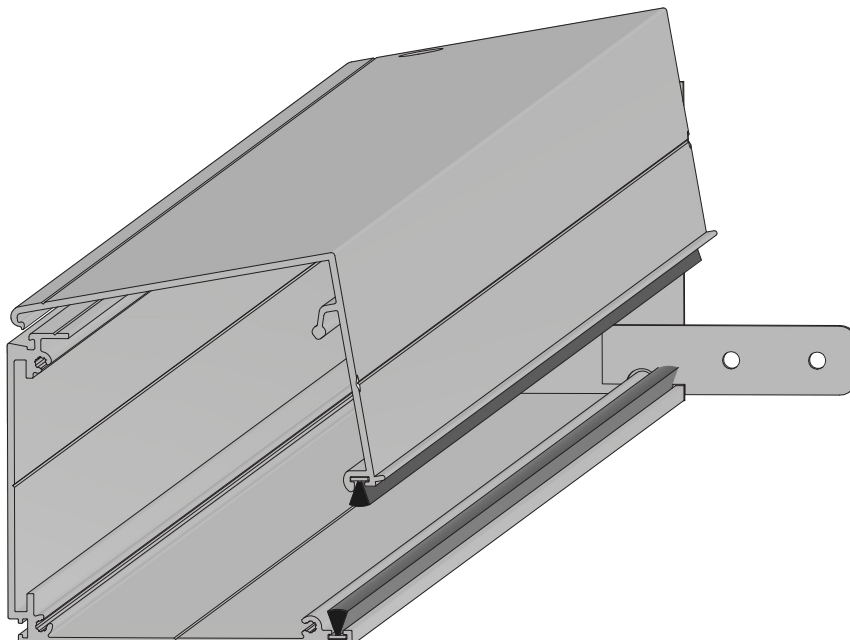

## STEP 2A

Fit the roller blind into the headbox.

Unroll approximately 300mm of fabric, then fit the motor end of the roller blind into the bracket. Ensure the blind is rotated so that the motor cable exits in your desired location. The tongue of the bracket will locate into the plate on the end of the motor.

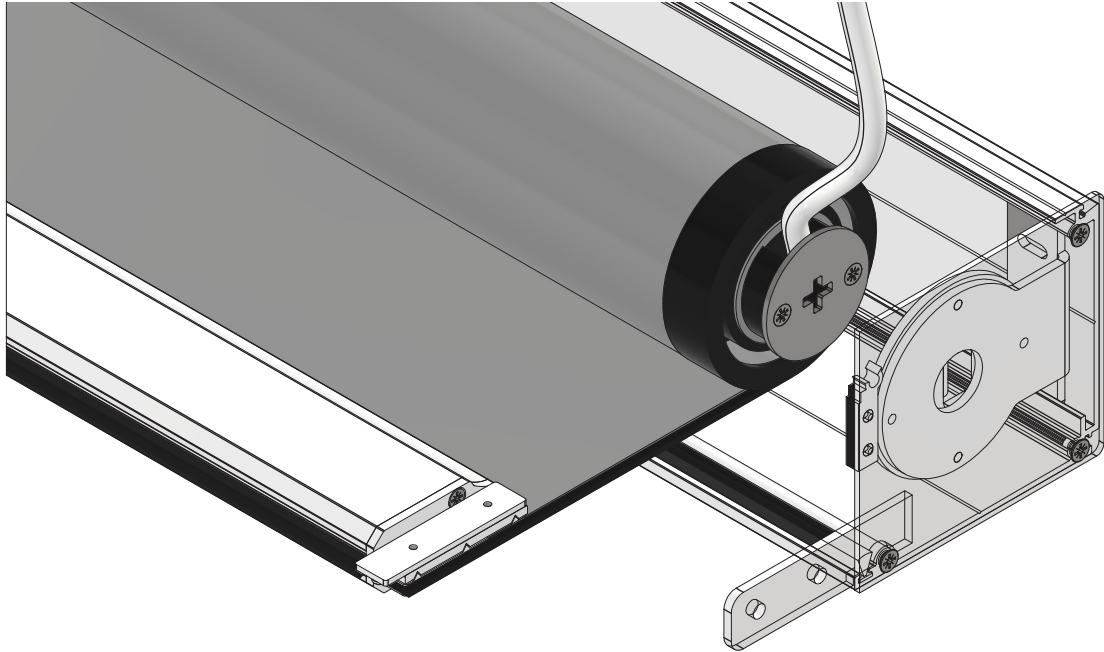

Remove the pin from the bearing and slide onto the tongue of the bracket, then replace the pin to prevent the bearing coming off the bracket. The blind should fit snugly between the brackets.

**WARNING:** If the blind is a loose fit between the brackets, do not continue with your installation, please contact your supplier.

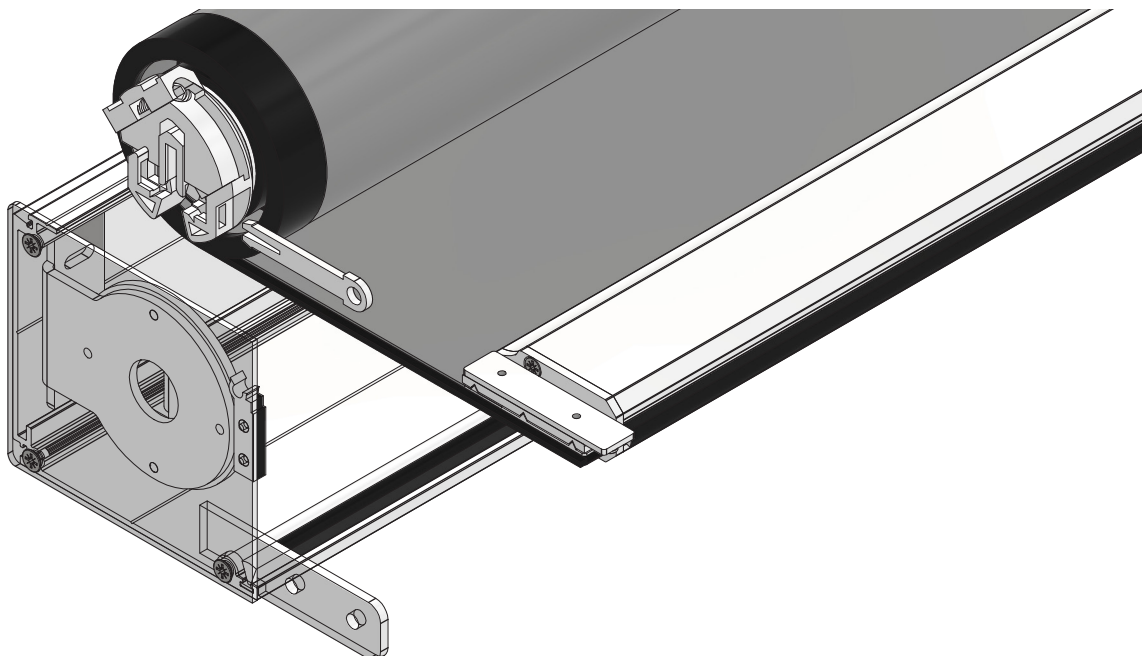

## STEP 2B

Inspecting your blind.

**PLEASE NOTE:** this only applies if your blind was already in the headbox.

Remove the screw from each end of the cassette containing the roller blind, then remove the front cover by hinging it up by approx. 8mm and sliding it back slightly to release.

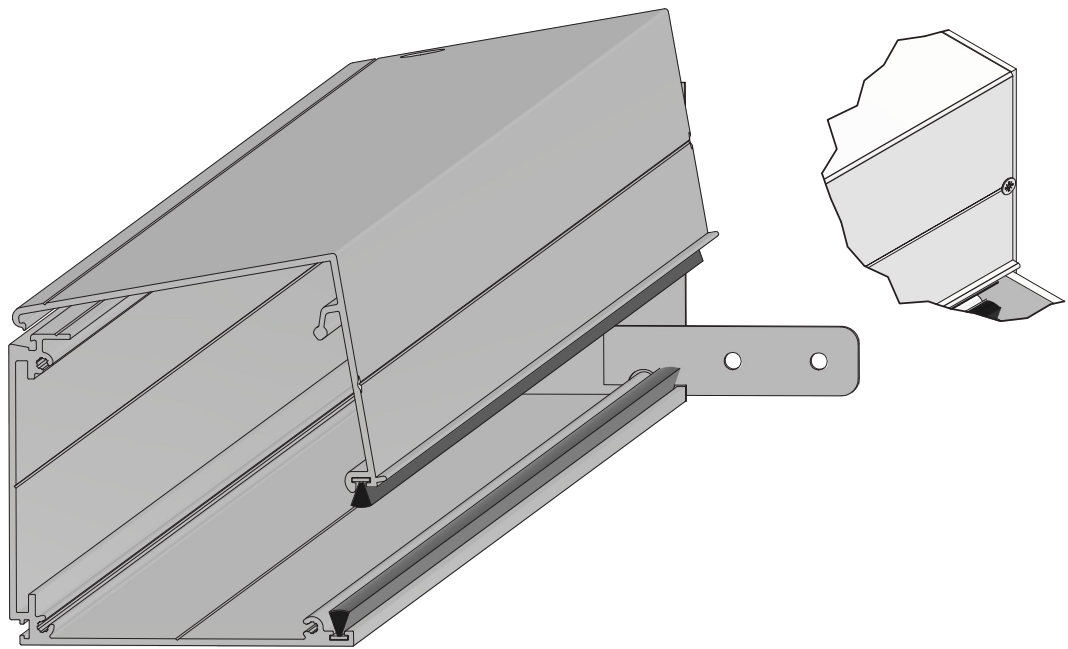

Inspect both ends of the roller blind for damage, and ensure there is no side-to-side movement between the brackets. If you are unsure of anything, please contact your supplier.

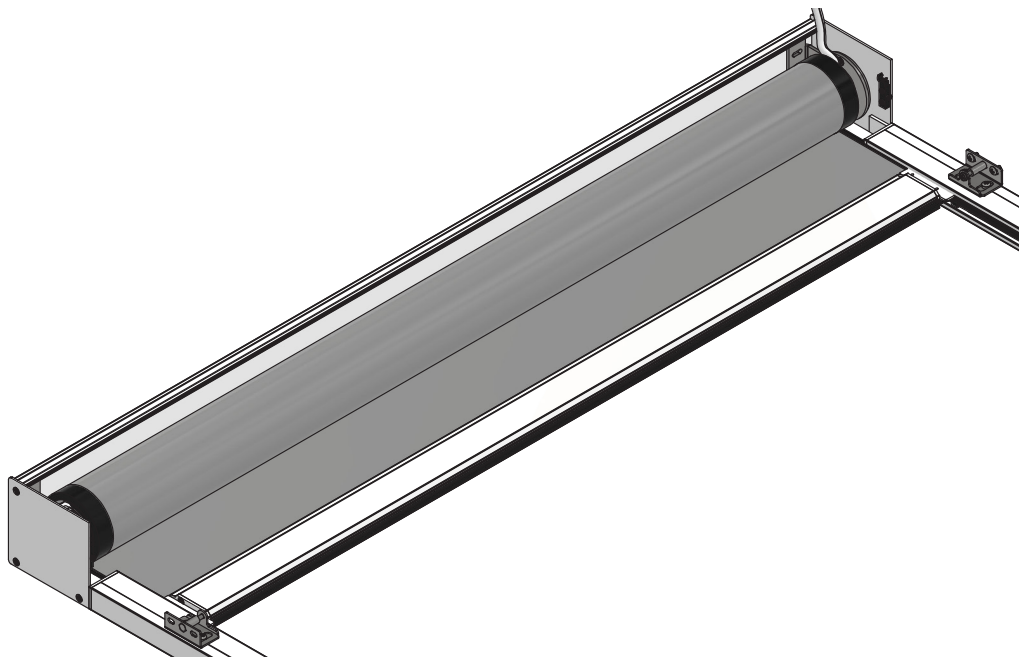

## STEP 3

### Assembling your blind.

Ensure the plastic insert is sitting correctly in the side channel, like this:

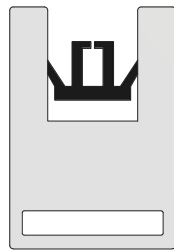

Slide the zip into the side channel, ensuring the teeth of the zip engage with the plastic side channel insert. Then slide the side channel onto the legs of the cassette end plates. Repeat this with the tension cassette, forming a frame on the floor.

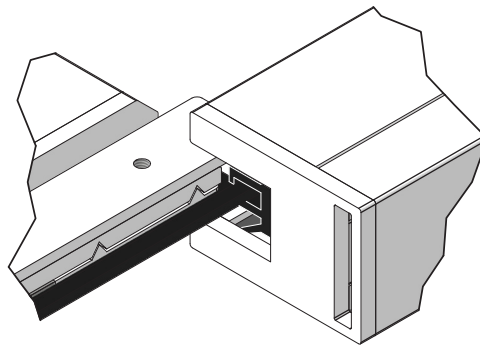

DETAIL C

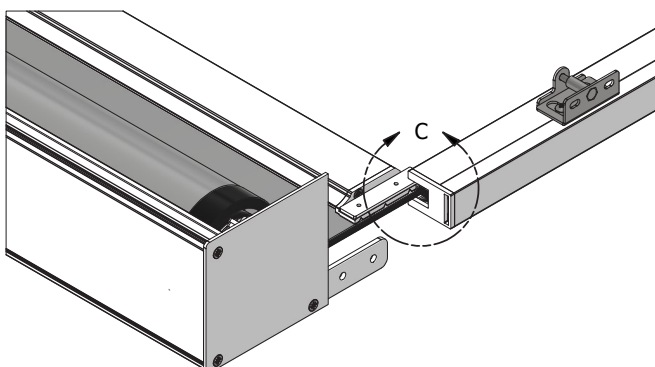

## STEP 4

### Preparing the tension cords.

Use a screwdriver or similar tool inserted through the ring on the end of the cord, and pull the cord approximately 100mm past the hembar of the roller blind.

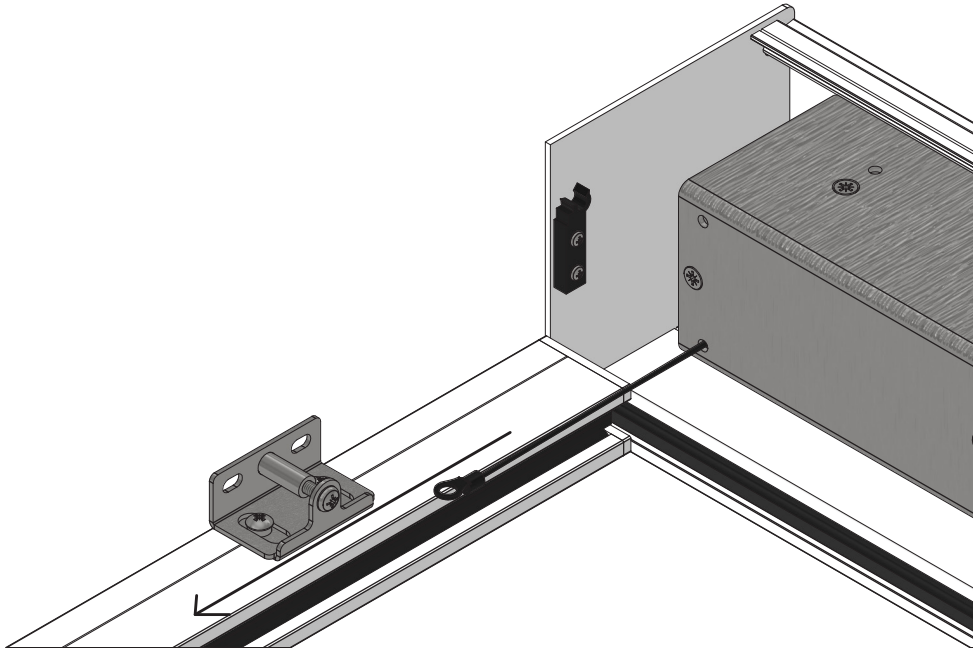

Use a suitable locking pin to lock the tension by inserting it into the locking point (see page 4). Gently release the tension onto the locking pin.

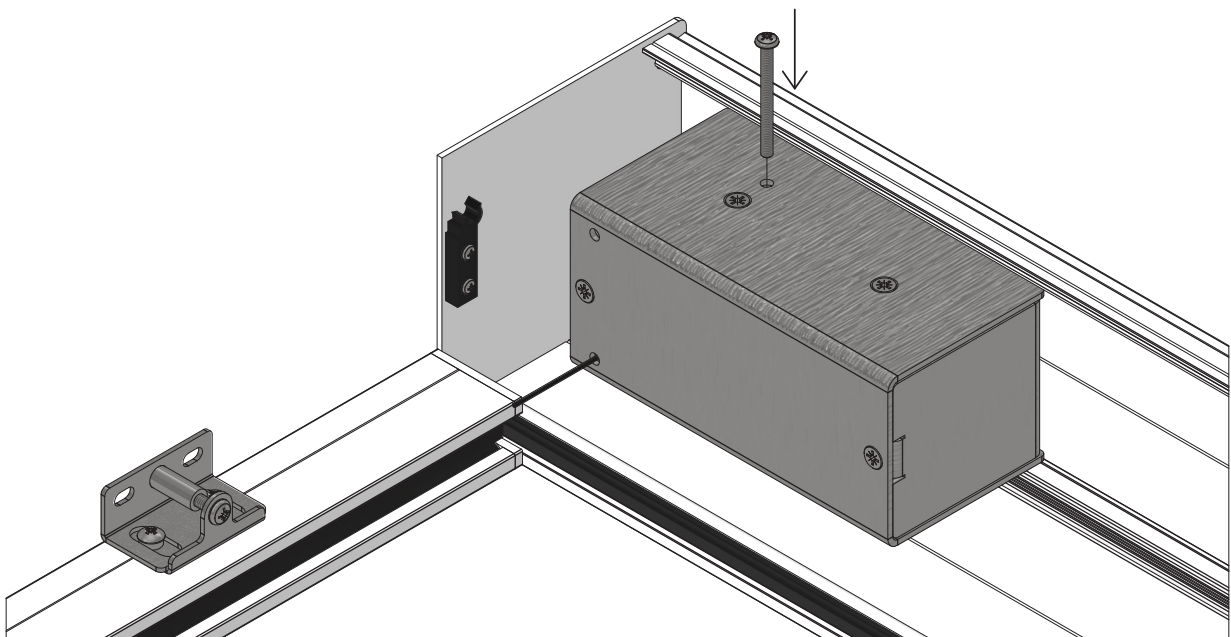

## STEP 5

### Attaching the tension cords.

Hook the ring on the end of the cord over the pin on the hembar endcap. DO NOT let the ring fall off the pin while the cord is slack.

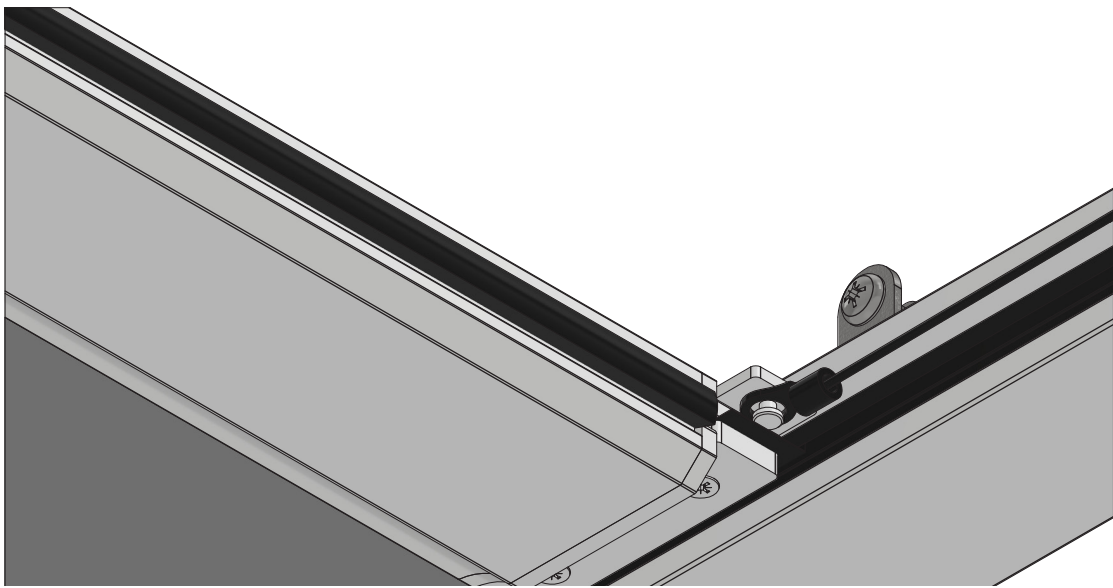

Take up the slack cord and remove the locking pin from the tension unit, and gently let the slack cord back into the unit.

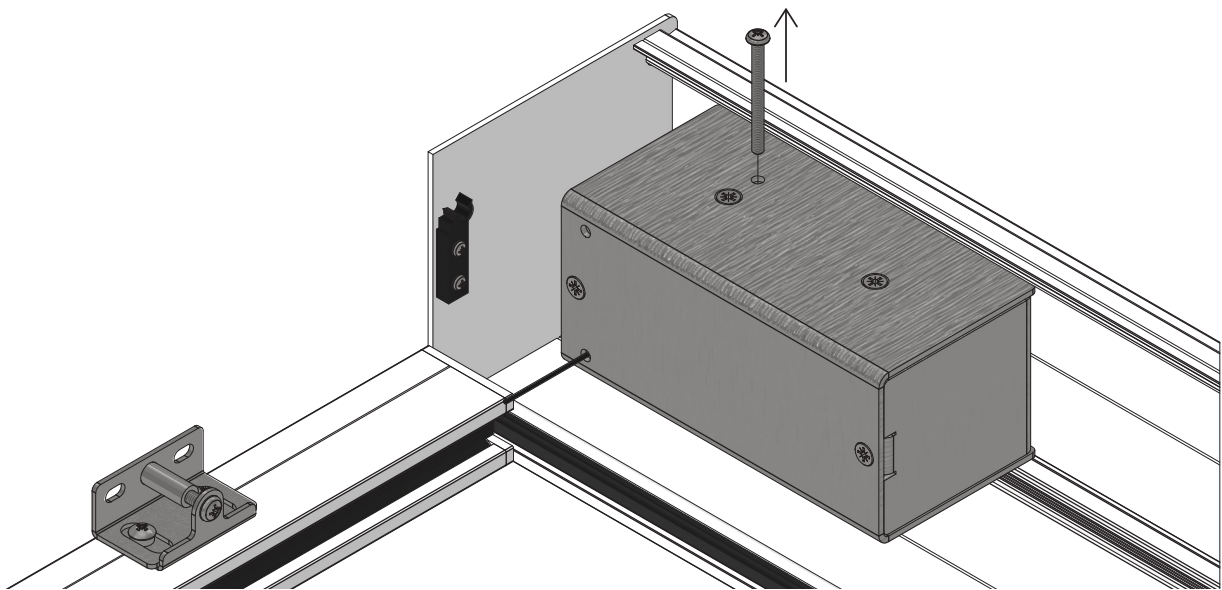

Under NO circumstances must the cord be allowed to return to the tension unit unchecked. This WILL damage the tension unit, and may also result in injury or damage to property.

## STEP 6

### Testing the blind.

Lift the blind off the floor to prevent fabric damage. You can use the corner supports of the packaging the blind came in for this.

Connect the motor to a temporary power source and fully close and open it to check that it's been correctly assembled. If it doesn't run smoothly, or doesn't stay in the side channels, refer to our trouble shooting guide here: <https://umbrashading.co.uk/troubleshooting-videos>

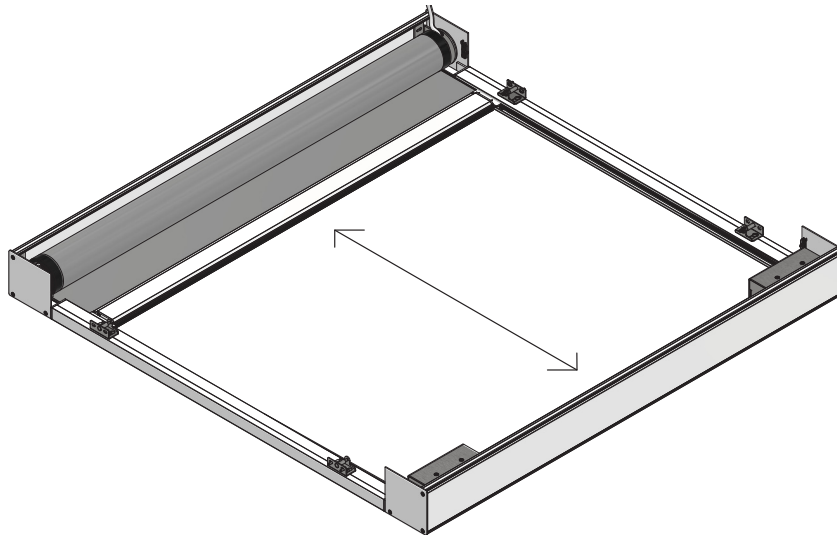

## STEP 7

### Motor commissioning.

You will have received a motor set-up card with your blind for the motor you are using. Scan the QR code on this card to view the setup video or PDF instructions for your motor. Alternatively, you can scan this QR code to go to our motor setup page to find the guide for your motor.



## STEP 8

Preparing the recess.

Mark the desired fixing height for your shelving. Refer to page 5 for more detailed fixing recommendations. Mark your fixing holes and pre-drill if necessary, then fix the shelf for the fabric end of the blind.

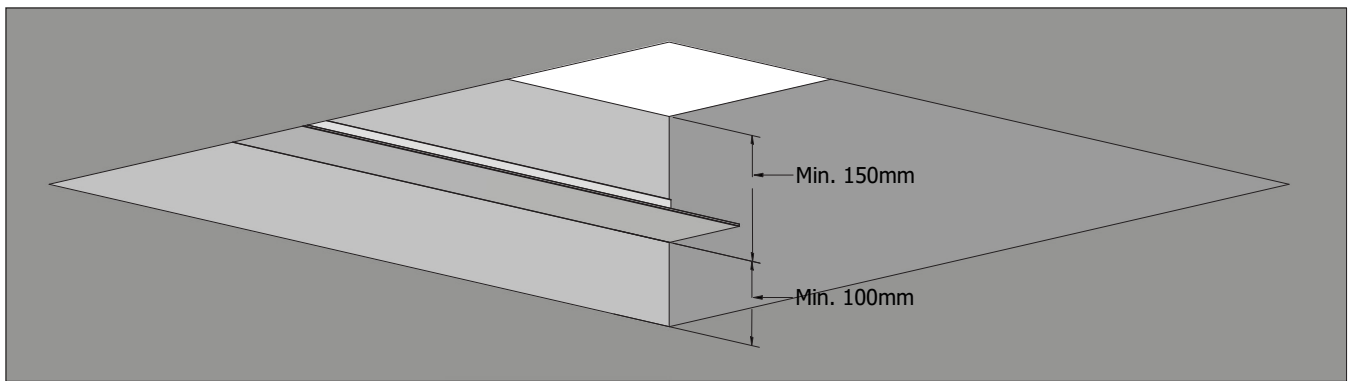

## STEP 9

Installing the blind.

Disconnect your blind from the power supply, and lift into place, resting the fabric end of the blind on its shelf.

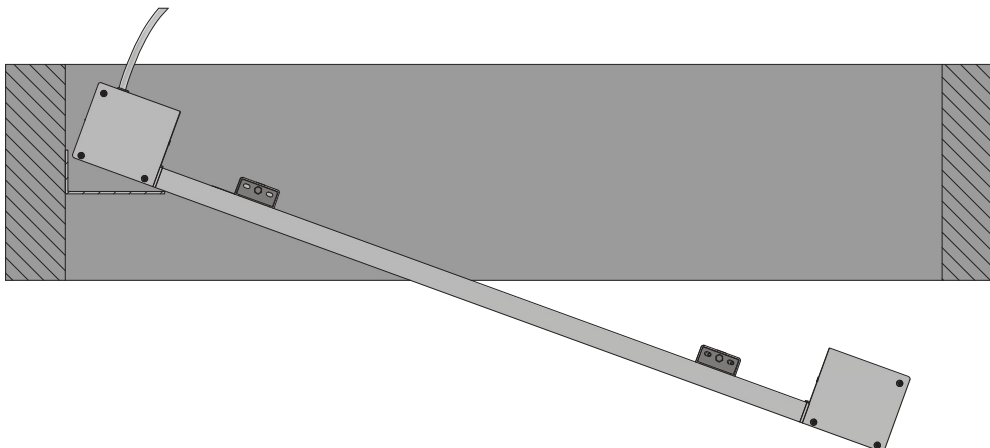

## STEP 9

### Installing the blind.

Fix the shelf for the tension end of the blind, then let the blind rest on the shelf.

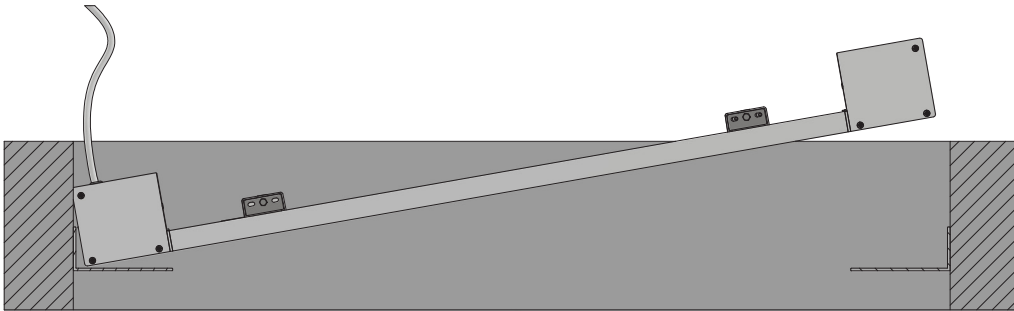

Fix the side angles into place. You can use the corner supports of the packaging the blind came in to prop the blind out of the way.

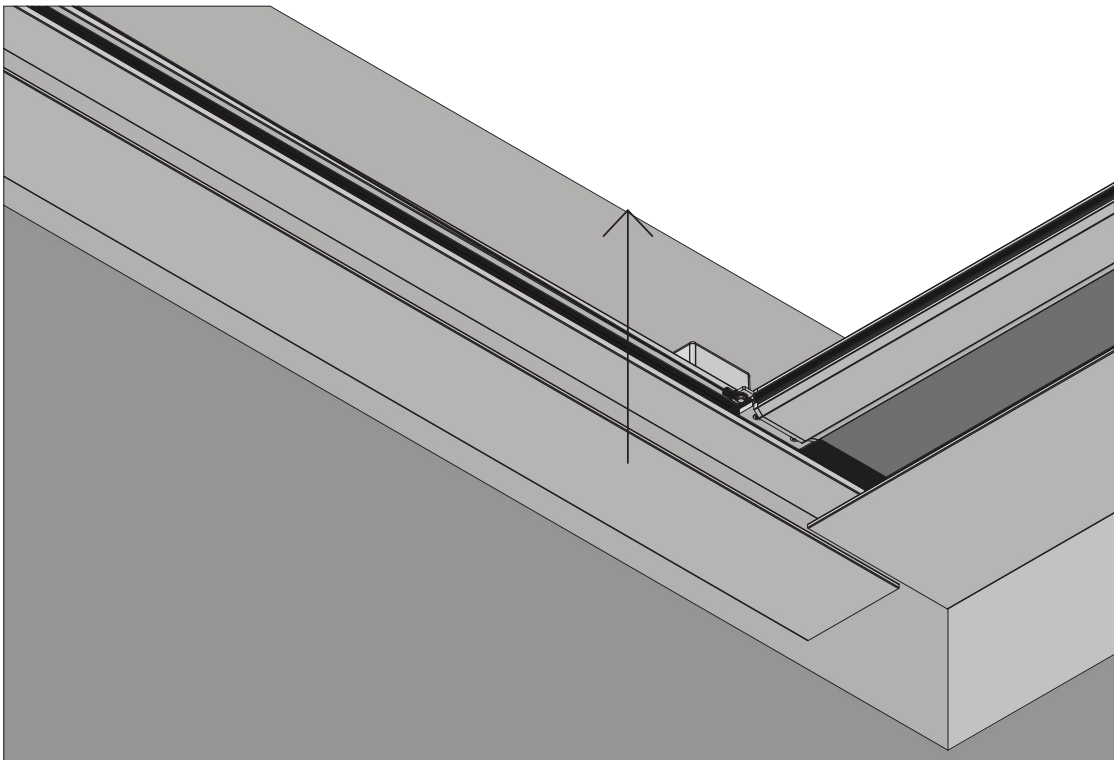

## STEP 10

### Fixing the blind.

Check the blind is square by measuring the diagonals. They should be equal. When fixing the brackets in place, measure at each fixing point to ensure the channels are the same distance apart across the whole length.

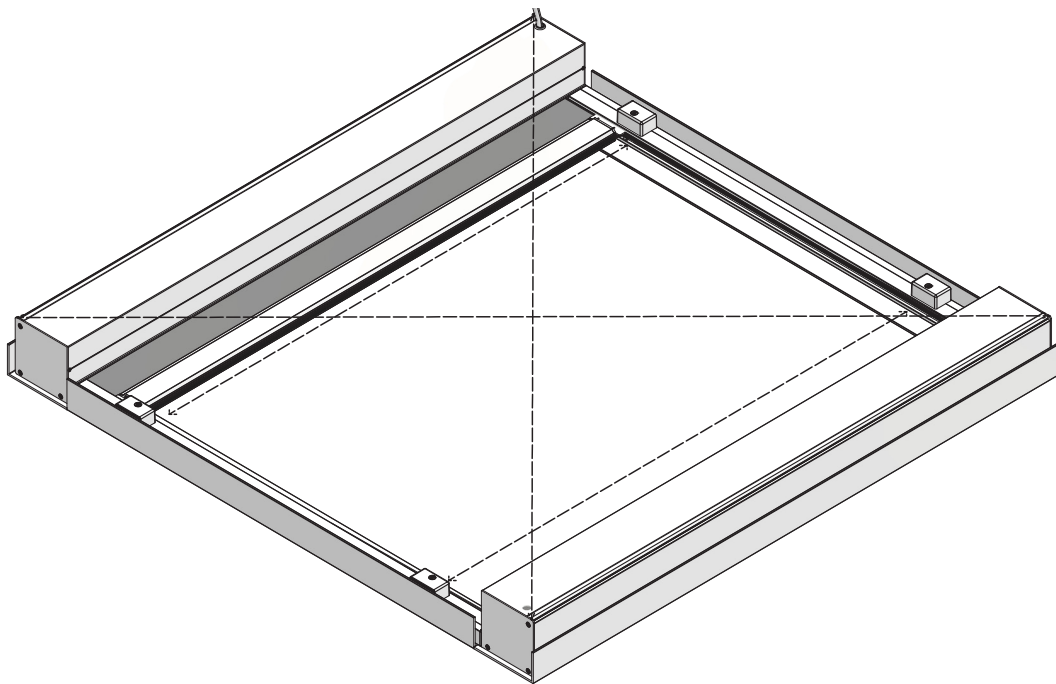

Fix the brackets into place using the screws provided.

**PLEASE NOTE:** these fixings can **ONLY** be used if your blind is being fitted on a shelf.

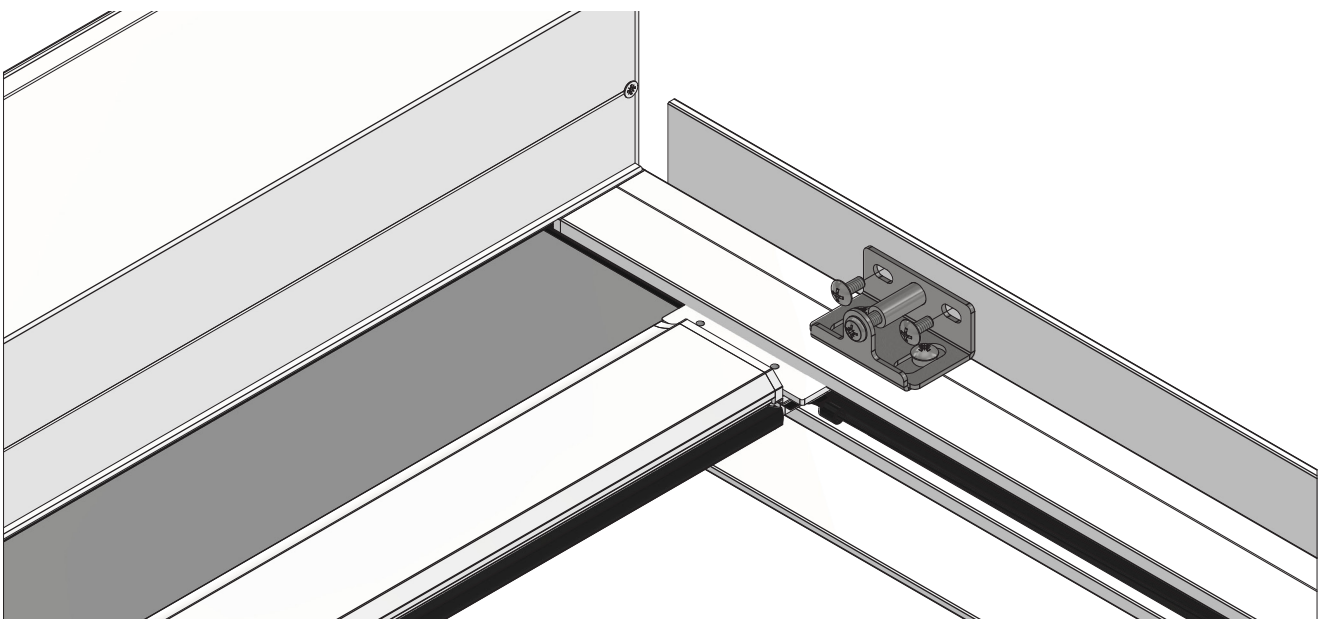

## STEP 11

Connecting the blind to power.

Re-fit the cassette front covers, ensuring you thread the cable through the cable exit grommet on the fabric end. If a cable exit was not specified on the order, you will need to drill your own with a 13mm drill bit, and fit the supplied grommet.

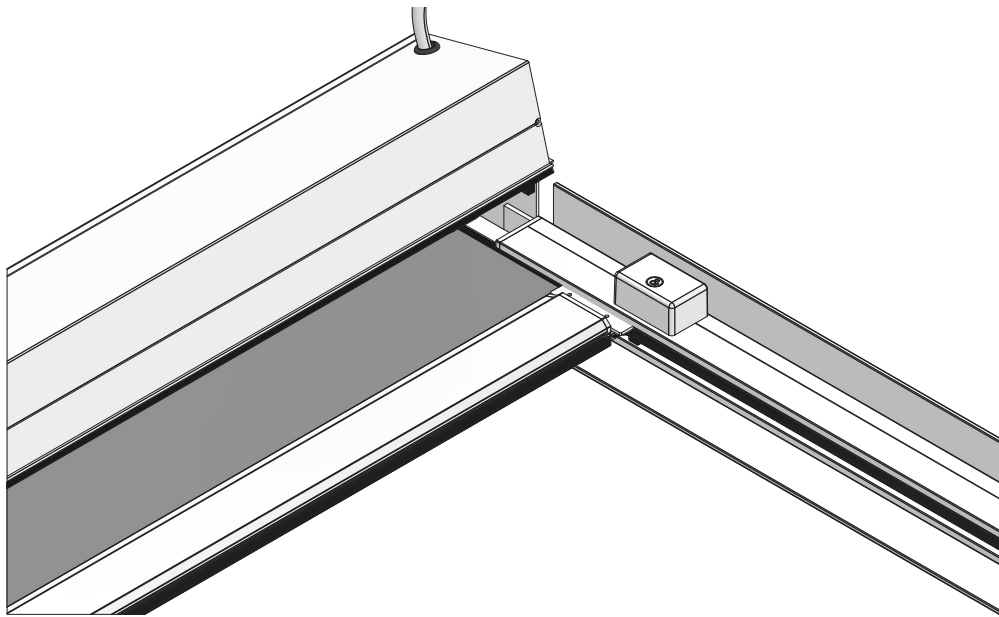

Connect the blind to your permanent power supply, and fully close and open it to test it. Ensure you leave a 5-10mm gap between the hembar and tension end box when closed. This ensures the blind is still under tension - the gap will be hidden by the shelf.

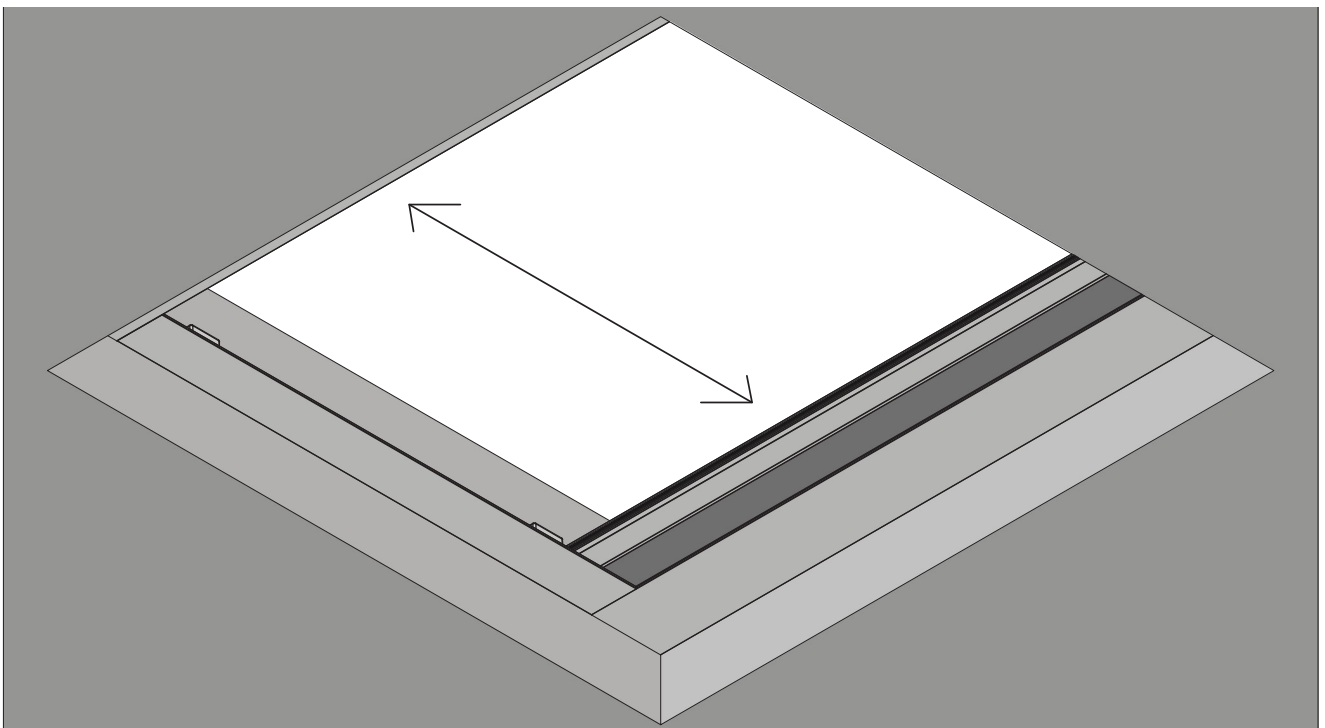

## STEP 12

Adjusting the blind (if necessary).

If the blind isn't running smoothly, or doesn't fully close, it may be necessary to slacken the screws on the adjustable brackets to improve the running of the blind. Alternatively, you may be able to tighten the screws and keep the fabric flatter. If your blind still isn't running correctly, visit our trouble shooting page here: <https://umbrashading.co.uk/troubleshooting-videos>

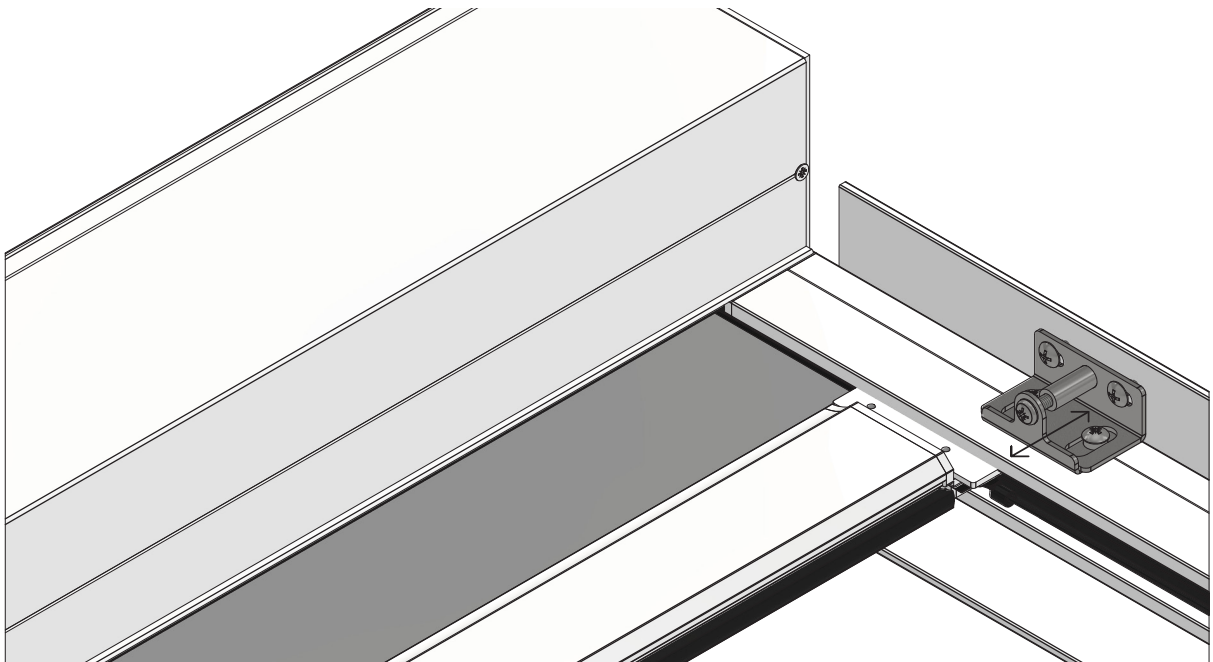

Fit the bracket covers back onto the channel brackets.

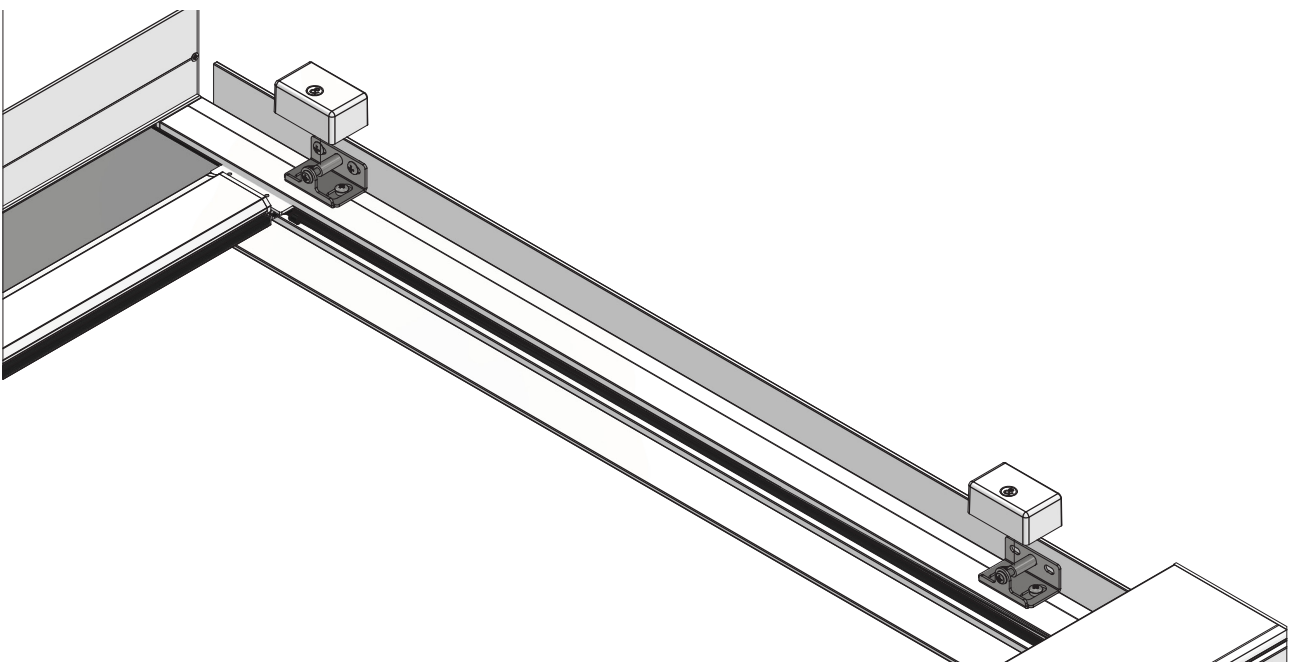

Your installation is now complete.

