

3D Printer
Farm



THE POSSIBLE ZONE



Dremel 3D Printer

THIS GUIDE IS NOT A
SUBSTITUTE FOR TRAINING OR
FOR THE USER MANUAL. THIS
GUIDE SERVES AS A REFRESHER
ONLY. USERS MUST BE
CERTIFIED TO USE EQUIPMENT
INDEPENDENTLY.

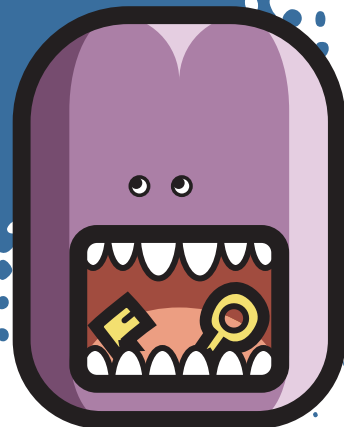

Last Modified: July 3, 2024 12:10 PM

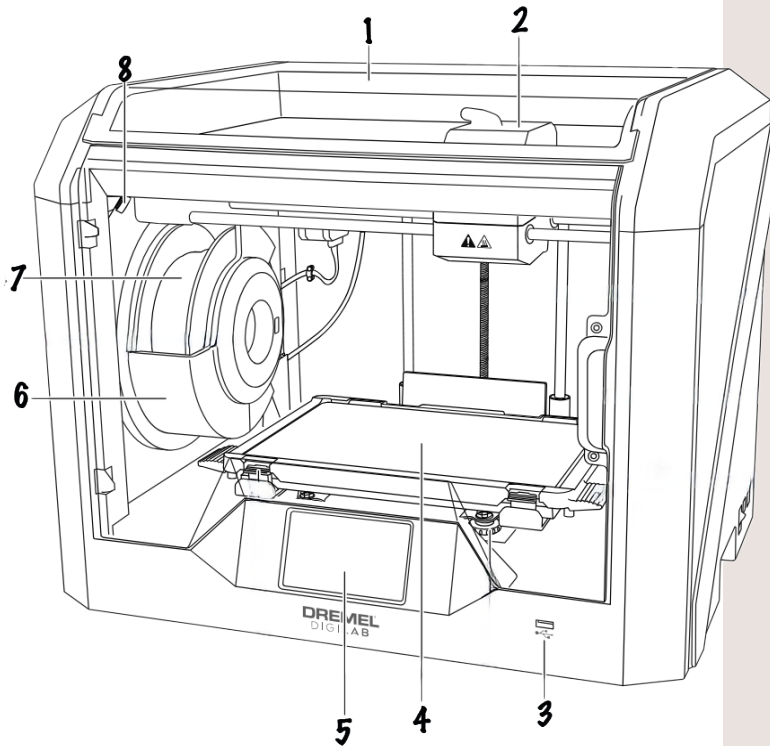

- 1. Lid:** Allows for more access to the build platform, extruder, ect.
- 2. Extruder:** An assembly that uses gears to pull filament through the extruder intake, heat the filament to the build temperature, and push the heated filament out of the extruder tip.
- 3. USB Drive port:** Additional way to send files to 3D printer
- 4. Build Platform:** The flat surface used by your Dremel 3D45 to build objects.
- 5. Touch Screen:** Full color display that is touch activated.
- 6. Filament Spool Holder:** A plastic piece located inside the Dremel 3D45 build area that is designed to hold a filament spool.
- 7. Filament Spool:** Storage for filament, a threadlike strand of plastic material
- 8. Camera:** Able to remotely watch your 3D prints

THIS TOOL IS PRIMARILY FOR:

THE DREMEL 3D PRINTER IS UTILIZED FOR CREATING THREE-DIMENSIONAL OBJECTS. 3D FILES ARE CREATED AND **SAVED AS AN STL. FILE** OR PRINT DIRECTLY FROM TINKERCAD.

HOW DO I MAKE A FILE TO PRINT?:

NURBS 3D MODELING SOFTWARE

NURBS MODELING ARE GREAT FOR PRECISION AND SMOOTH SURFACE CREATION, MAKING IT SUITABLE FOR ENGINEERING AND DESIGN.

-SOFTWARE: **ONSHAPE**, SOLIDWORKS, FUSION 360, RHINO

MESH 3D MODELING SOFTWARE

MESH MODEING IS MORE FLEXIBLE MAKING IT POPULAR IN ENTERTAINMENT AND REAL-TIME APPLICATIONS

-SOFTWARE: **TINKERCAD**, MAYA, ZBRUSHCOREMIN, 3DMAX

MATERIALS

PLA [POLYLACTIC AID] MATERIAL ONLY

- + BLUE PLA
- + PINK PLA
- + ORANGE PLA
- + WHITE PLA
- + PURPLE PLA
- + BLACK PLA
- + YELLOW PLA
- + GREEN PLA
- + TRANSLUCENT PLA

DREMEL 3D PRINTER

KEEP IT SAFE

TAKE PROPER SAFETY PRECAUTIONS WITH OPERATING EQUIPMENT

Pg. 3



The nozzle gets VERY HOT, typically reaching up to 210°C (410°F). Keep your hands and fingers clear of the hot-end at all times. Let any filament that comes out cool for 5 seconds before handling or removing.



Do not reach inside the Dremel 3D45 while it is in operation. Contact with Dremel 3D45 moving parts during operation may result in poor build quality, equipment damage or personal injury.

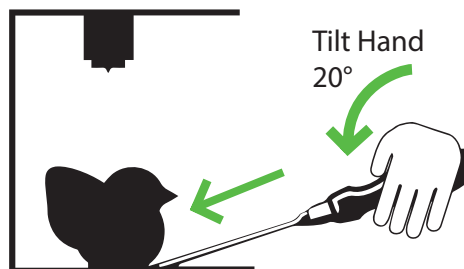

Every printer comes with a scraper (putty knife) to help remove prints. These are SHARP, so always push away from yourself when removing a print and keep your hands clear of the edge.

LOG IN

- Head to Jumpcloud at <https://console.jumpcloud.com/>
- Log in with your TPZ username and Password
- Click on the green (3) icon labled 3D Printer
- See Set Up Documentation QR.

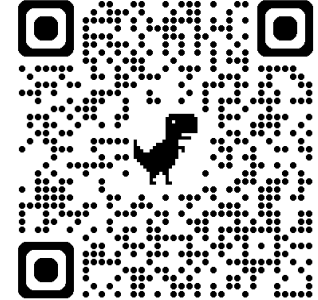
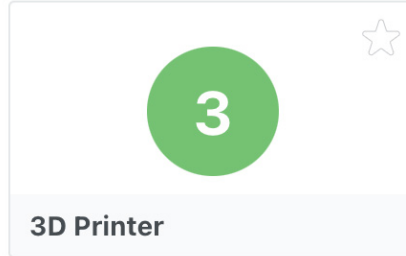

3DPRINTEROS SITE

- Once you are logged into 3DPrinterOS Site click on
 1. Files to see new models
 2. Projects to see past models.

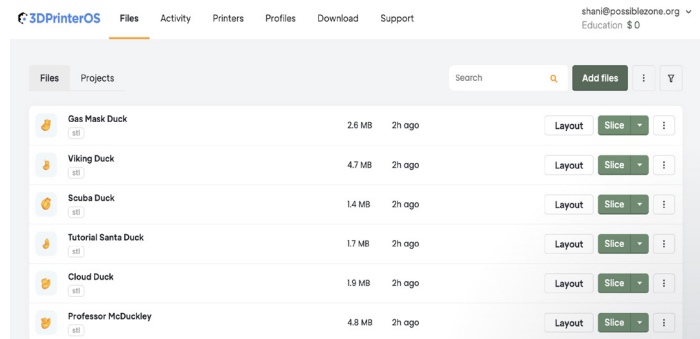

SENDING FILES FROM TINKERCAD TO 3DPRINTEROS

1. Log into Thinkercad at <https://www.tinkercad.com/login>
2. Once signed into 3DPrinterOS using JumpCloud log into your Tinkercad account by heading to
3. Click on **Designs**
4. Select a model you would like to print
5. Click on **Tinker this**

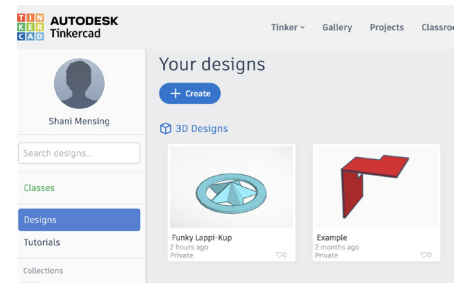

Funky Lappi-Kup

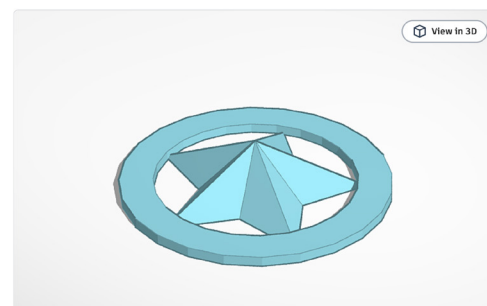

React ❤️ 0

3D Design by Shani Mensing

Tinker this

Download

Share to Classroom

Copy link

Design is visible only to you. [Change visibility to share](#)

Edited September 26, 2023
Created September 26, 2023

© 0 0

SEND MODEL TO 3DPRINTEROS

- To send files to 3DPrinterOS click on **Export** on the upper right hand side of the screen
- Click on **3D Print**
- Select **3DPrinterOS**
- Hit continue to **3DPrinterOS** if prompted
- You will then be directed to 3DPrinterOS
- Your model will now appear under **Files**
- Head to section below to print model

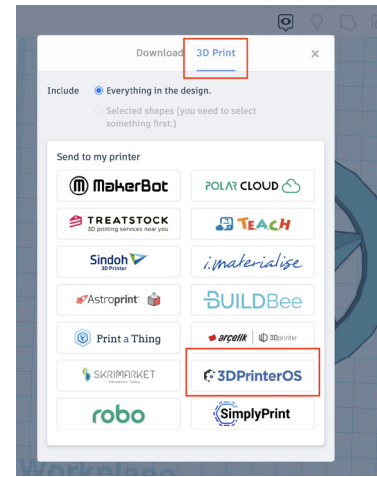

PREPARING MODEL TO PRINT IN 3DPRINTEROS

- Double click on the file you would like to print or select Layout to open the Layout page
- Move, scale and rotate model as needed.
- Always click **On Bed** and **Center**
- Click **Slice** when finished.

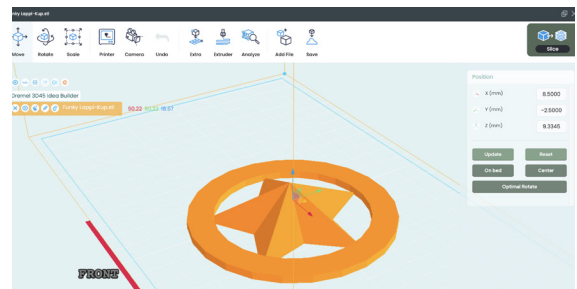

**THE FLAT SIDE OF THE MODEL SHOULD TOUCH THE BOTTOM OF THE PRINT BED!
TRY TO LAY DOWN TALL MODELS.**



PRINTING MODELS IN 3DPRINTEROS

- Profile settings will automatically be set for you.
- Take a moment to make sure that your settings reflect the setting shown here.
- Make sure **Generate Support** is checked
- Make sure **Build Plate** is set to **Raft**
- Next select **Slice & Toolpath Preview**
- Hit **Print** in the upper right corner
- Pick up Models in bin by 3D Printer Farm

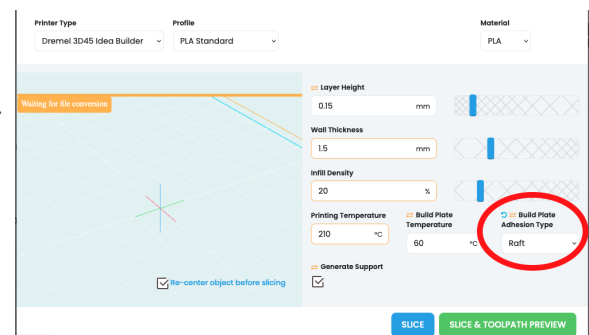



SET UP CONFIRMATION

USE THE FOLLOWING CHECK LIST TO INSURE THAT YOU HAVE SET UP THE MACHINE SAFELY AND PROPERLY.

THIS GUIDE IS NOT A SUBSTITUTE FOR TRAINING OR FOR THE USER MANUAL. THIS GUIDE SERVES AS A REFRESHER ONLY. USERS MUST BE CERTIFIED TO USE EQUIPMENT INDEPENDENTLY.

SELF CHECK

- Make sure the bed is clear before starting a print
- Arrange tall models to lay flat on the bed
- Make sure that Generate Support is checked
- Make sure build plate has a Raft
- Before starting job check the toolpath preview
- Make sure to not change Profile settings
- Do not touch moving parts of 3D Printer

CLEAN UP

- Remove Print from the bed
- Careful when removing material. Always push away from your body/ hands
- Clean up any filament strands in machine
- Put any unwanted material in the PLA recycling bin

This Machine Training Curriculum derives from the framework developed by Autodesk Pier 9 and posted on www.instructables.com/pier9/ Many thanks to the wonderful people of AutoDesk Pier 9.