

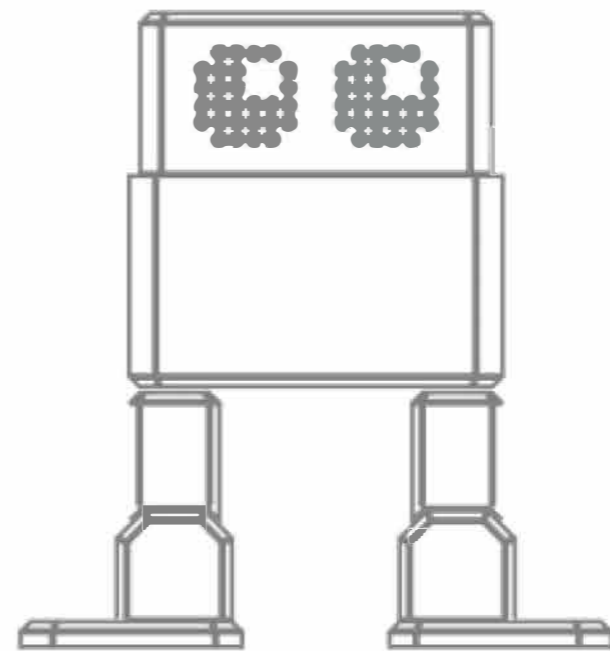

# Otto DIY builder kit

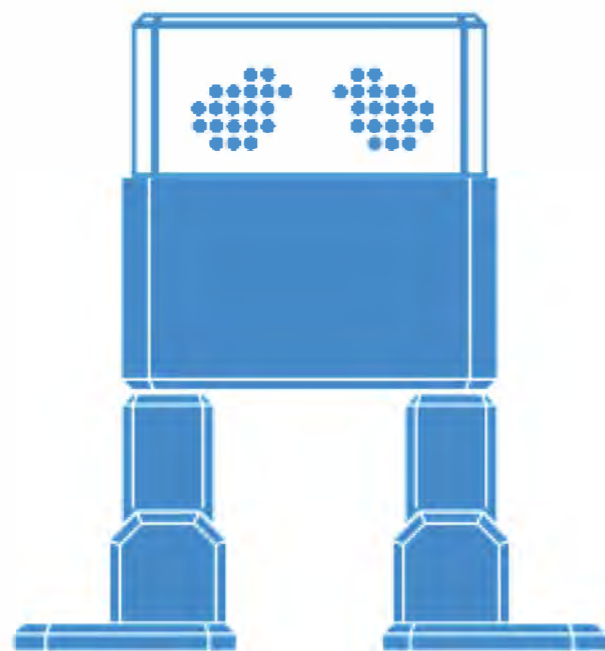

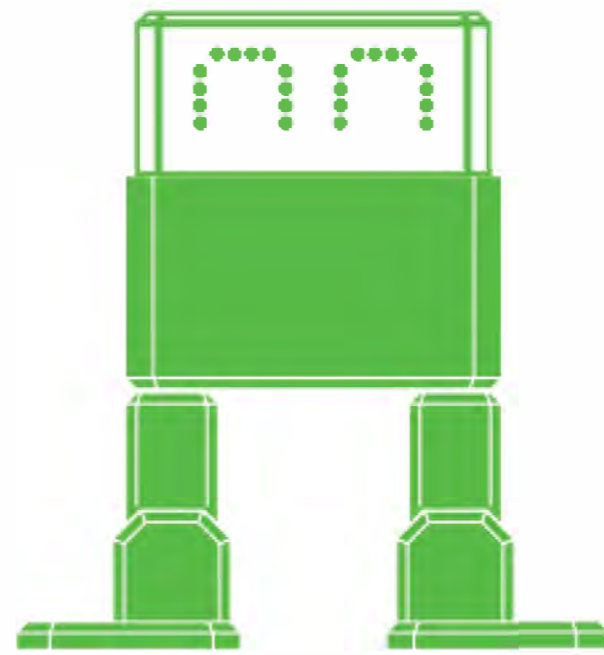
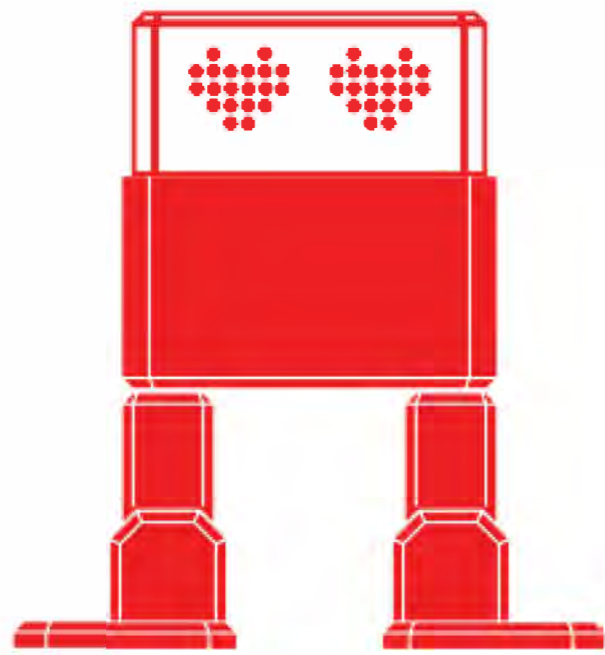

# 1

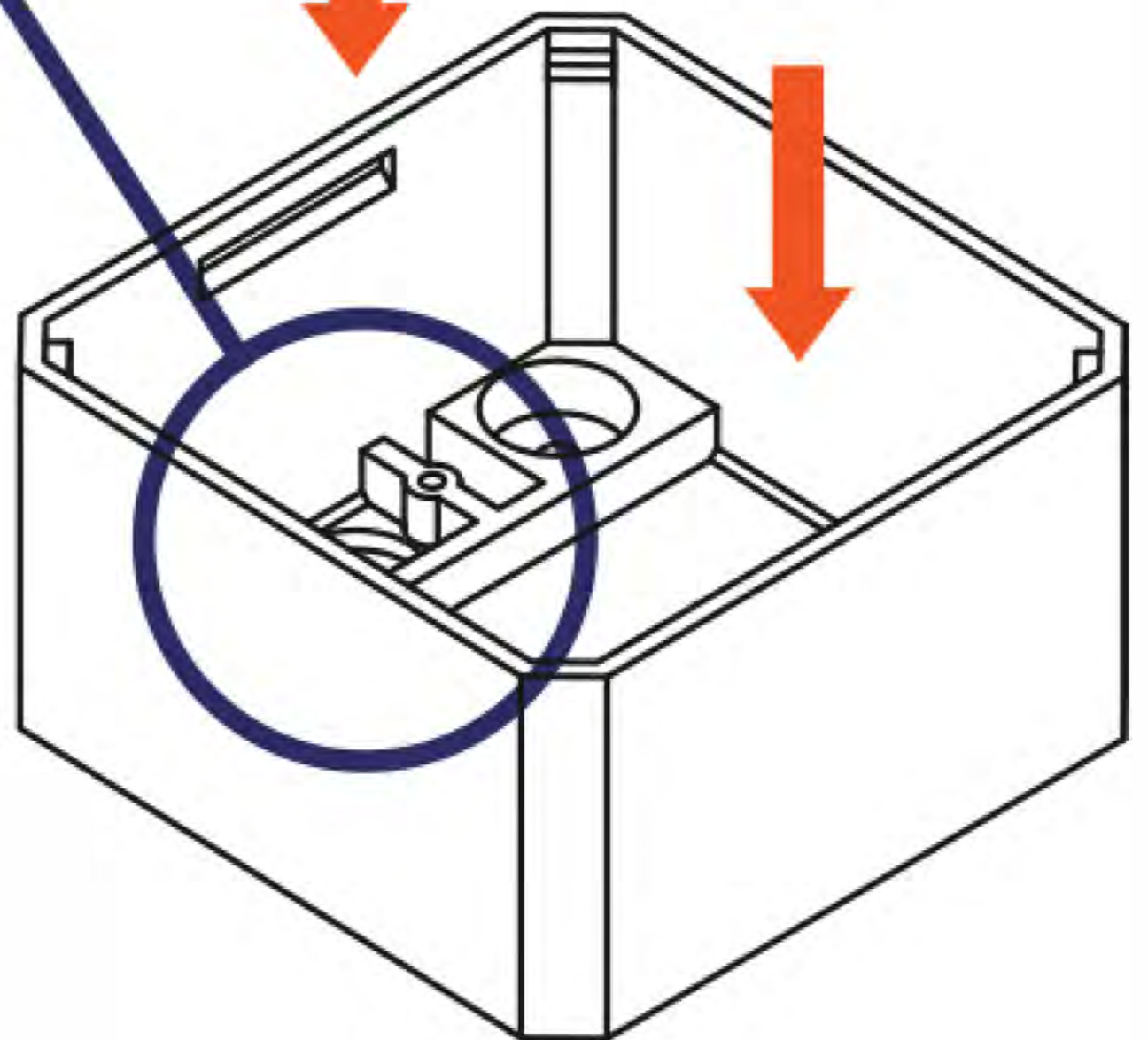
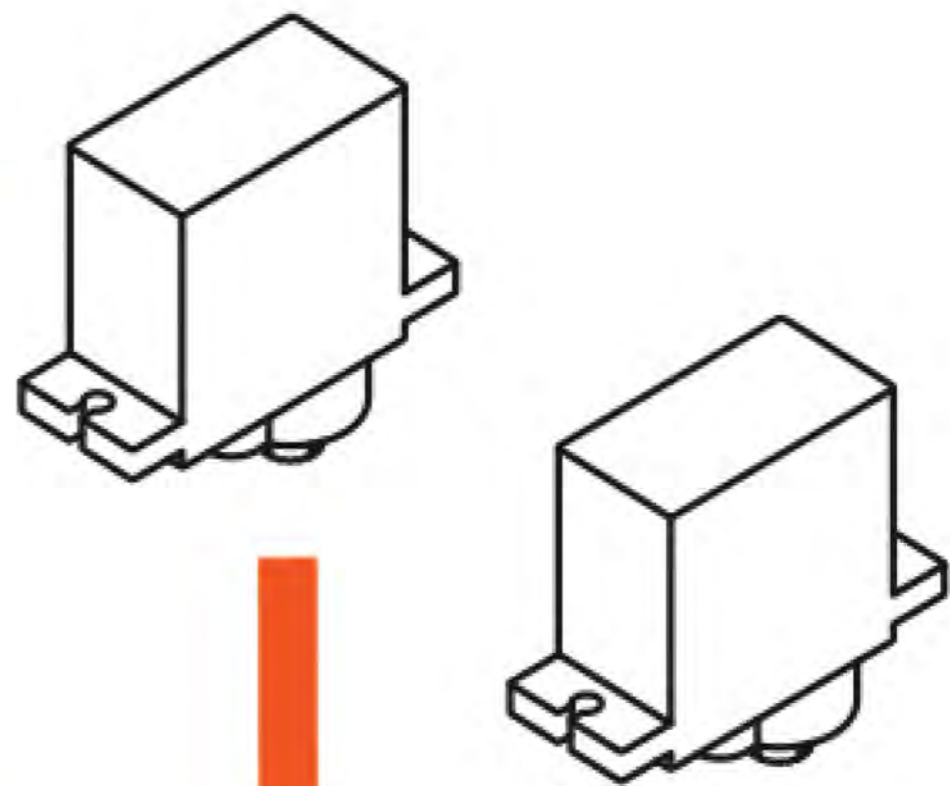
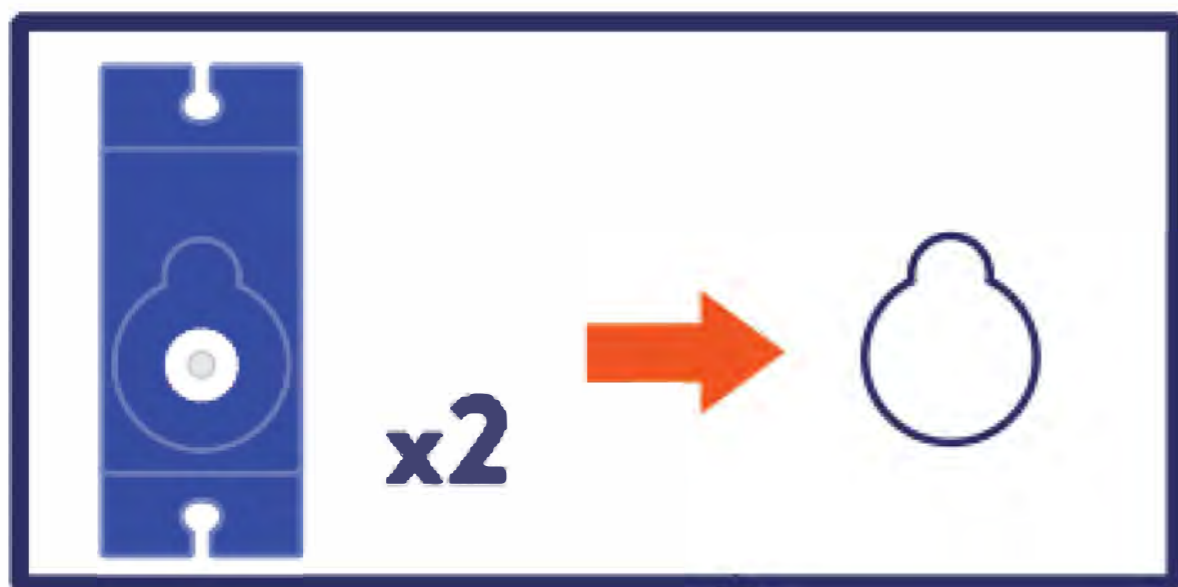

1. Grab Servo Motor
2. Line up Servo with matching whole in 3D model.
3. Slide servos in place.



# 2



1. Grab screwdriver

2. With provided screws,  
screw servos into 3D  
model.

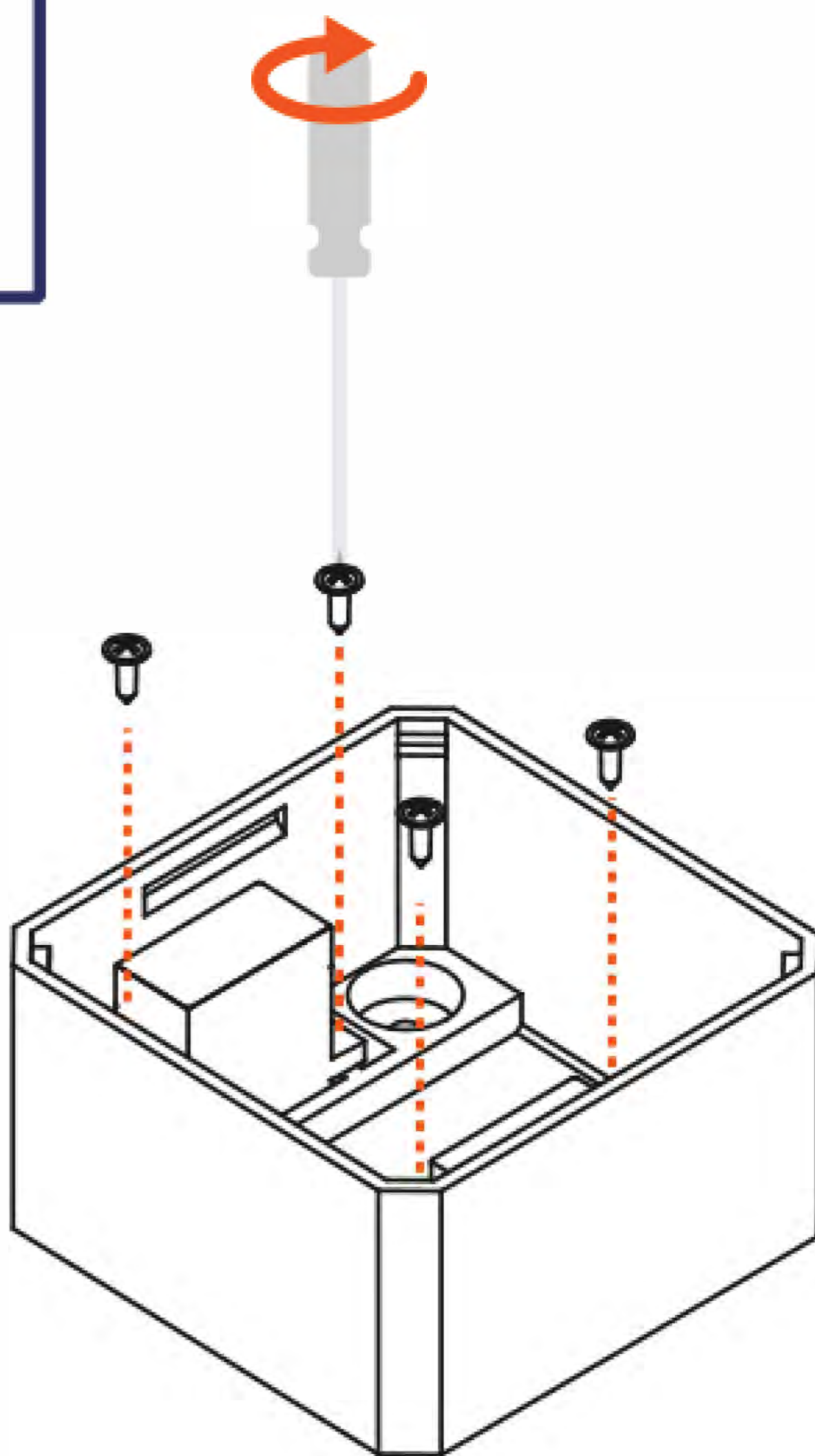



# 3

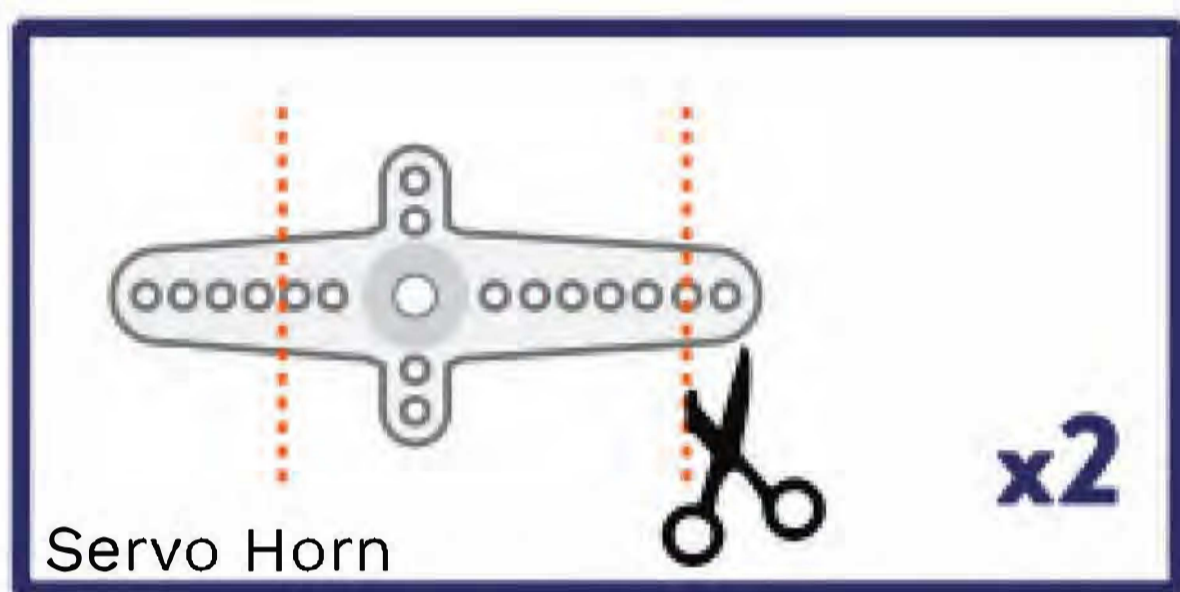

1. Take 2 provided servo horns and cut horns as shown on the left.

2. Place cut servo horns into the leg 3D model part.

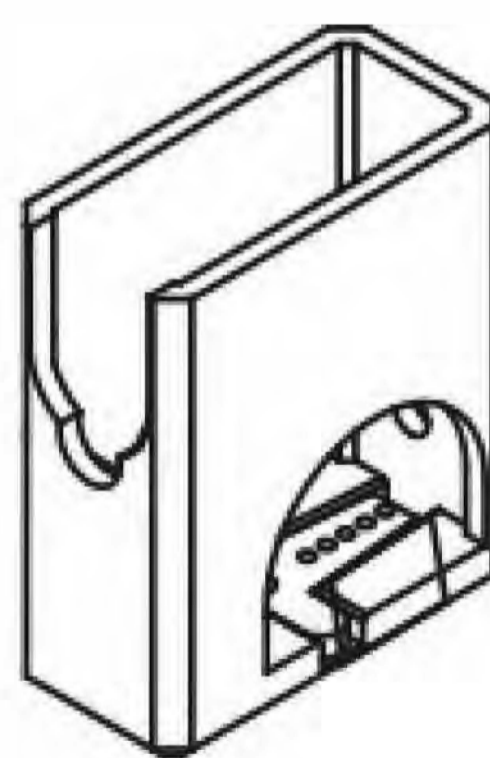
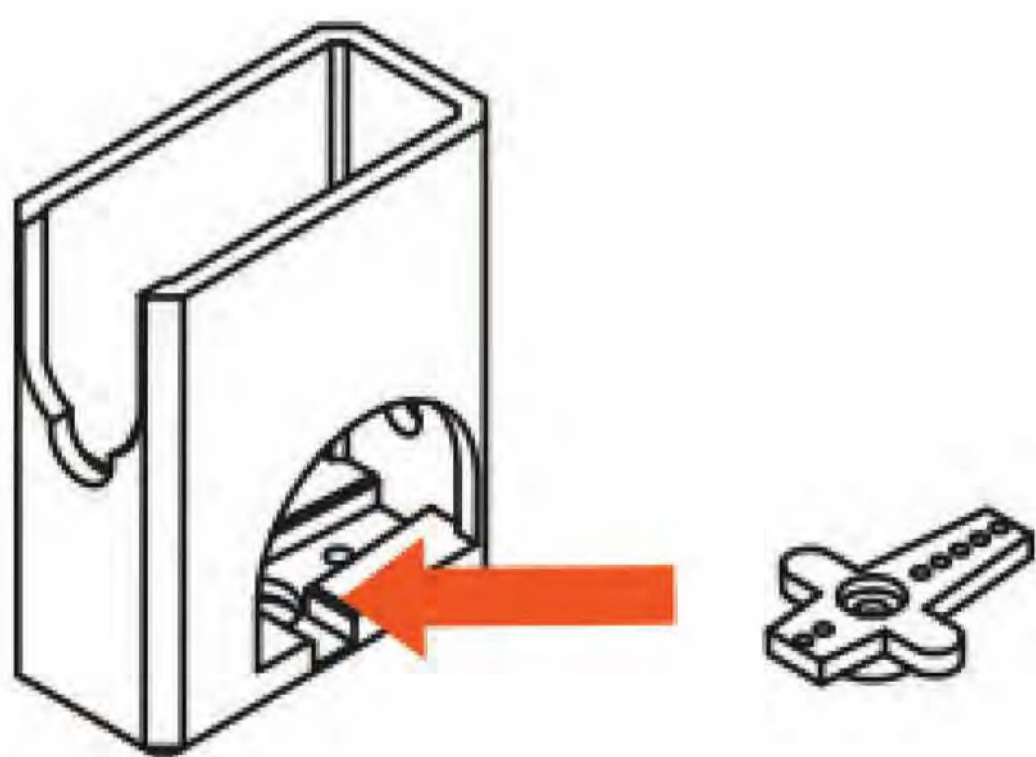



# 4

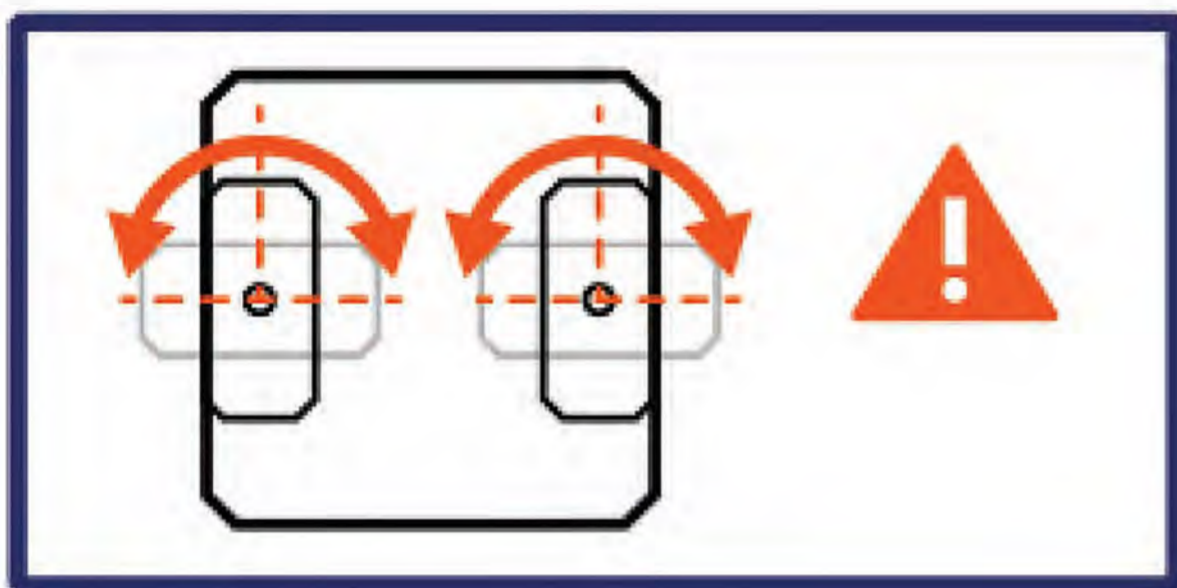

1. Grab body 3D model and turn model upside down.

2. You will see the servo gears peeking through the body model.

  
**180°**

3. Take leg 3D parts with the servo horn and place them on the 3D body so that the servo gear is inserted into the servo horn.

4. Make sure that the 3D legs are parallel to the 3D body before attaching.

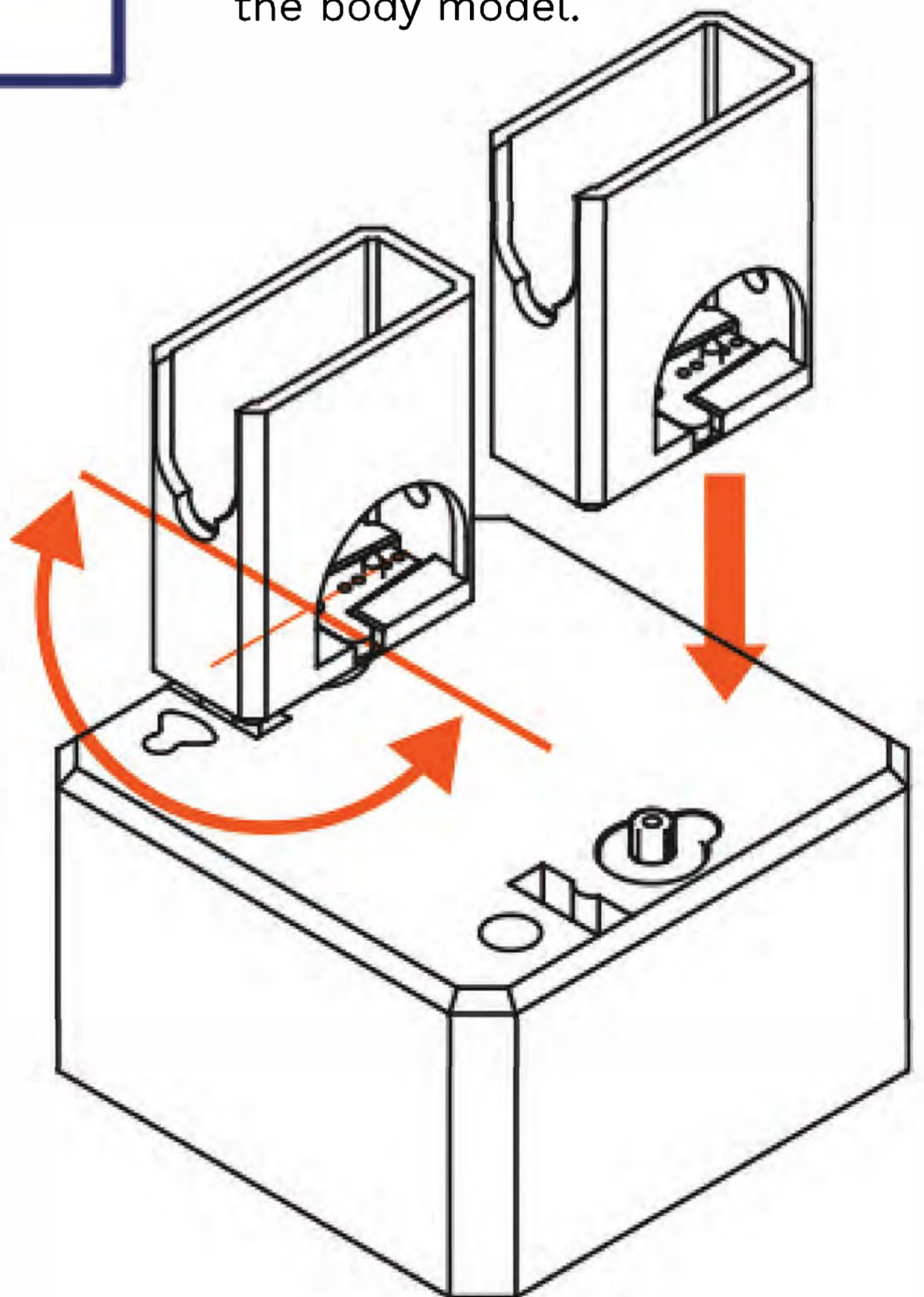



# 5

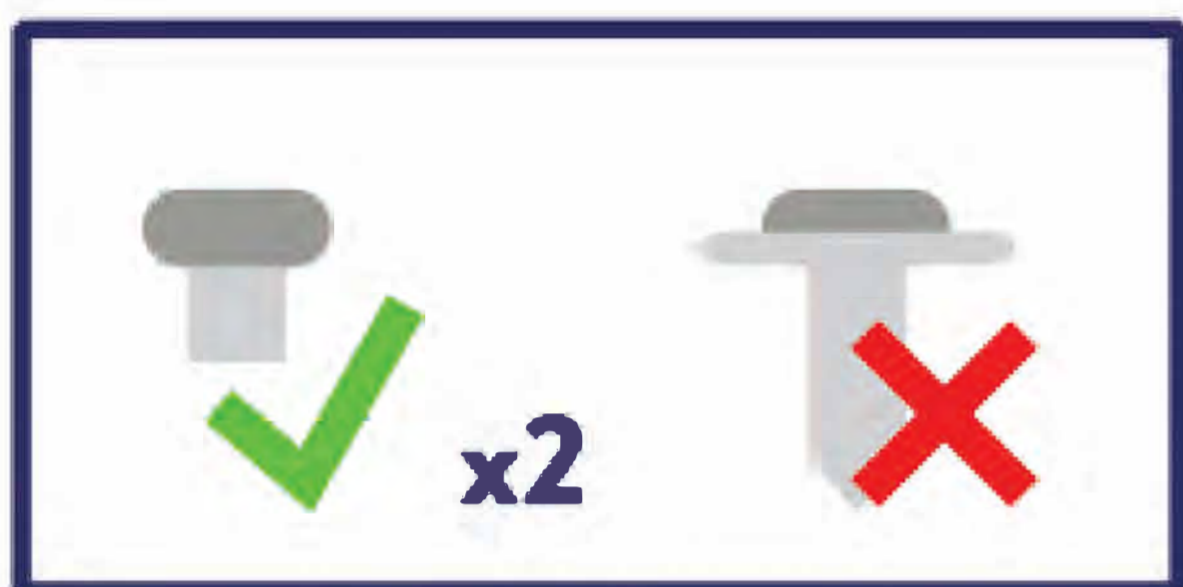

1. Once the servo gear is placed in the servo horn use the flat head screws to secure the legs to the servos in the body

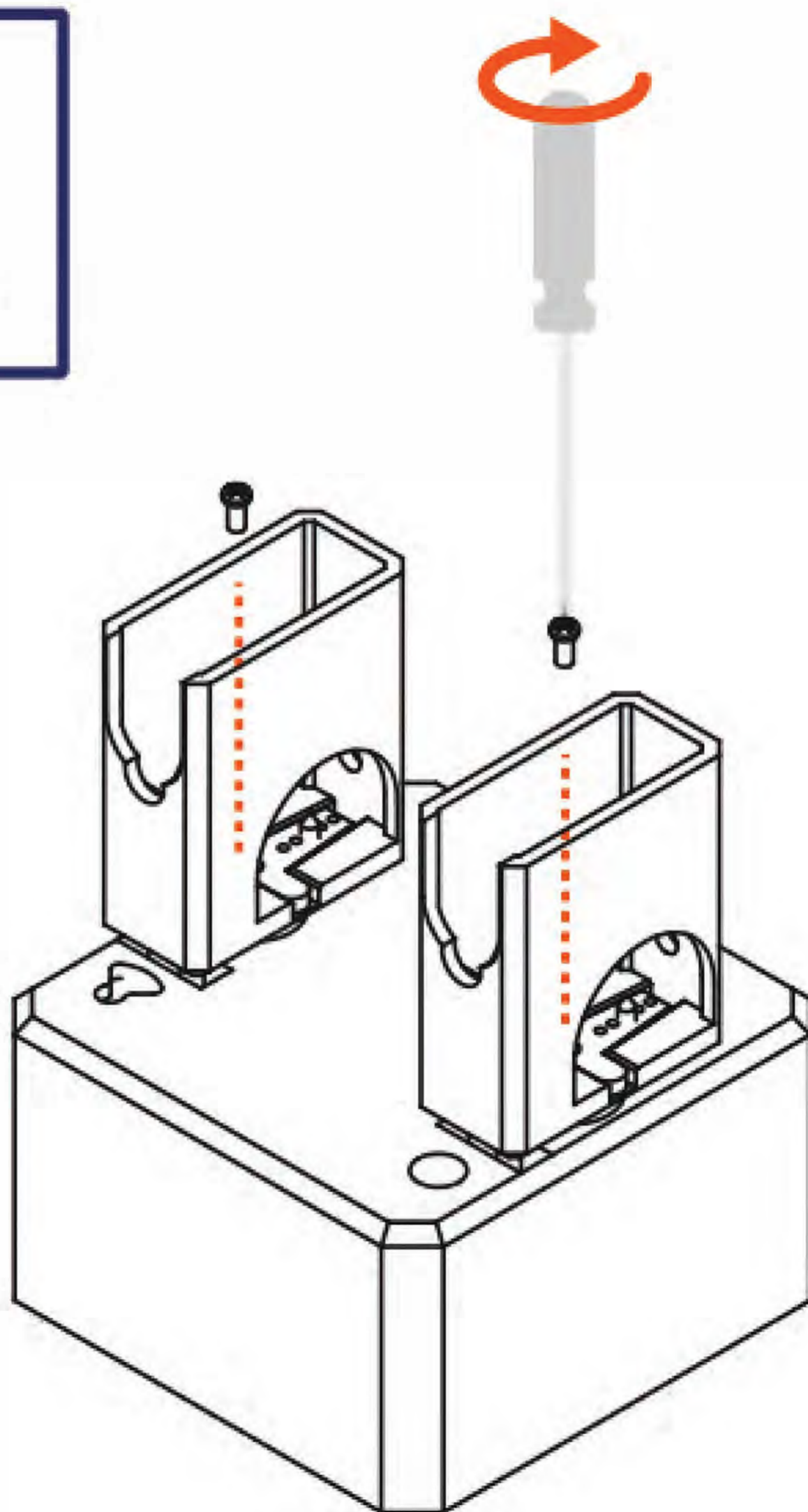



# 6

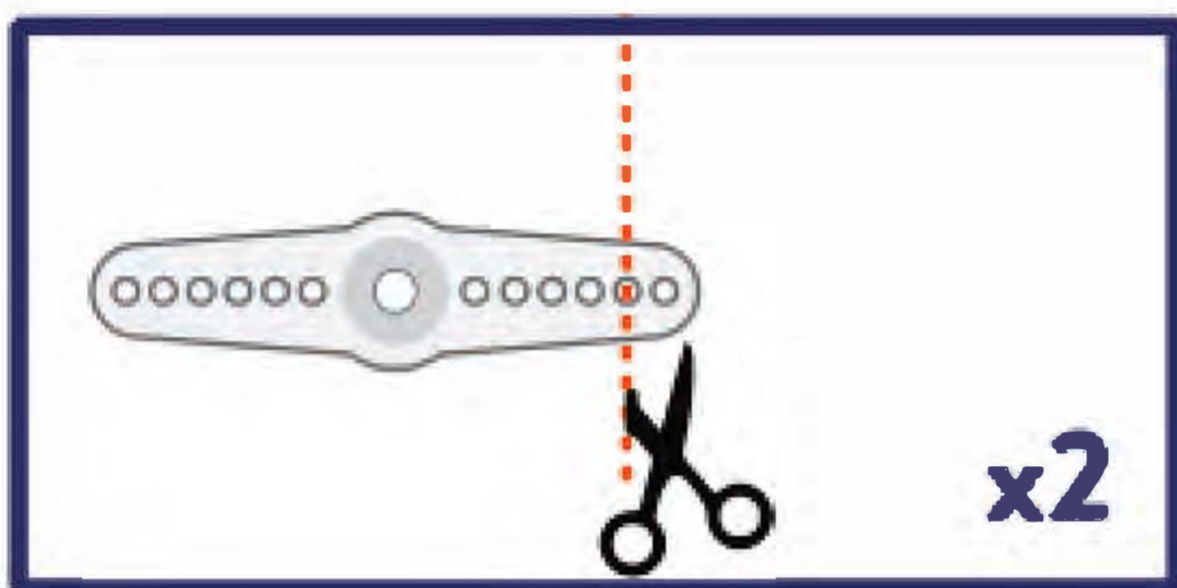

1. Next we will prep the servo horn and servo for the feet.

2. Cut the servo horn as seen to the left.

3. Line up servo horn so that it is vertical.

4. Place servo horn onto servo.

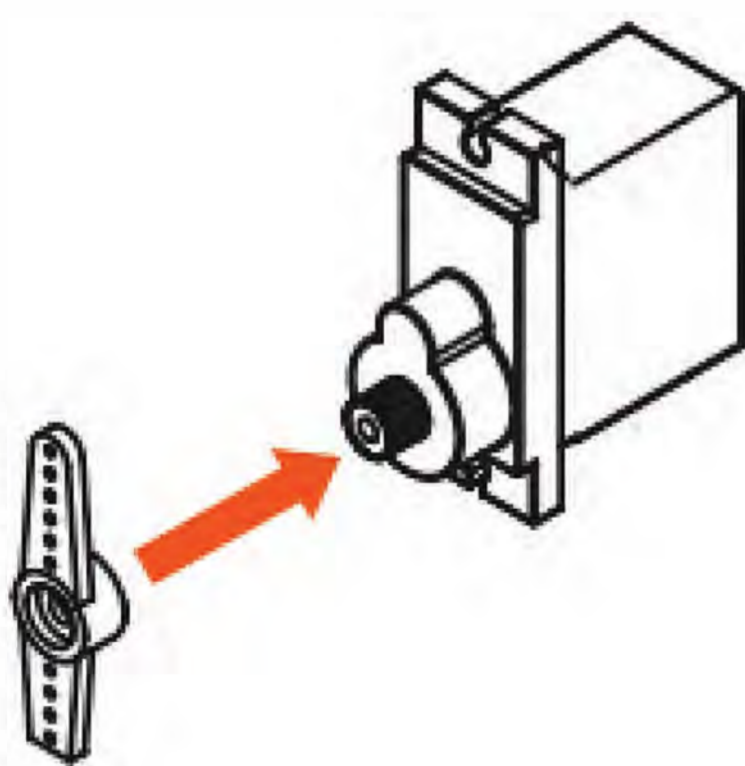



# 7

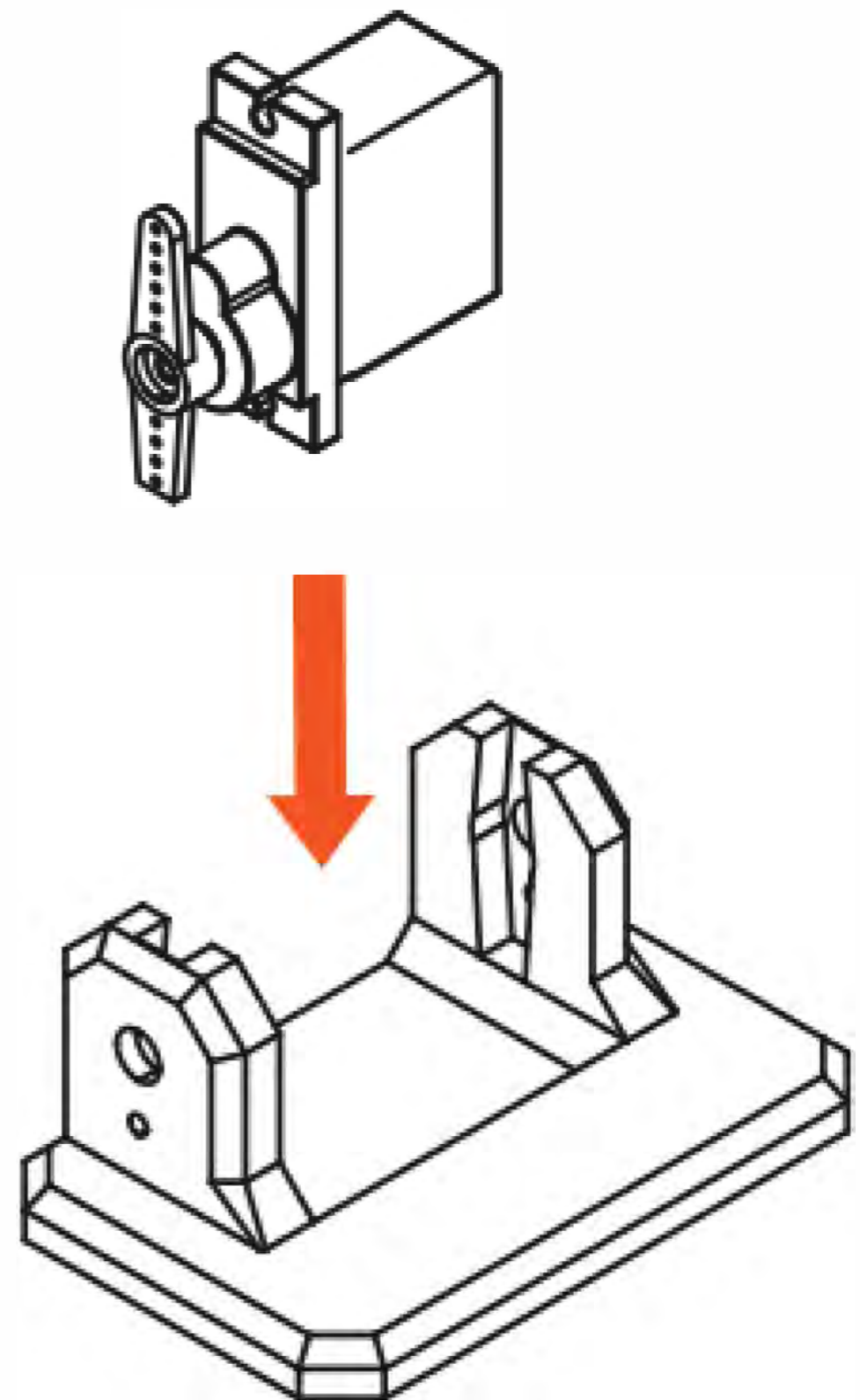
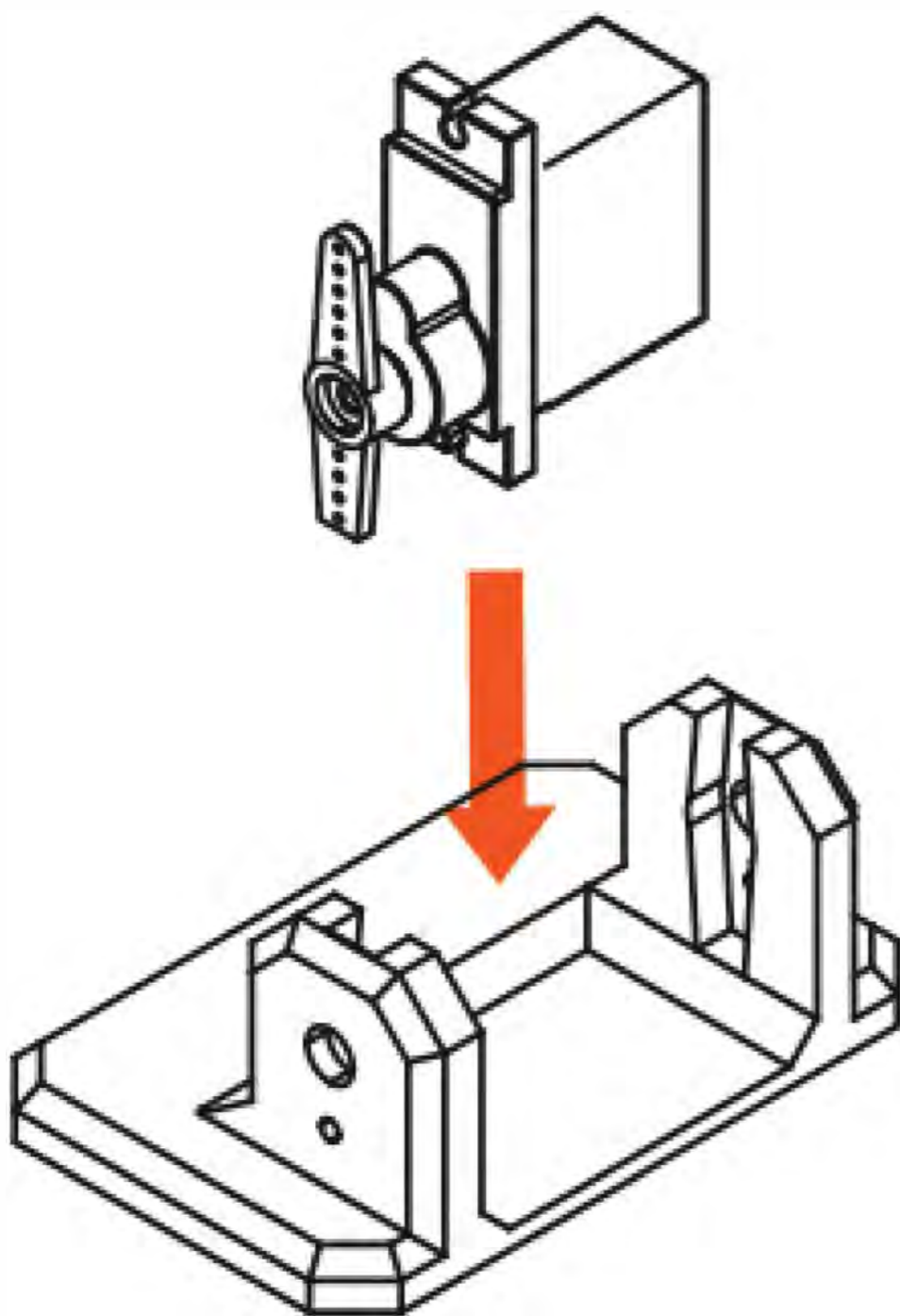

1. Repeat last steps again.
2. Set up feet so that they are facing away from each other as seen in image.
3. Place servo with horn into feet slot
4. Make sure servos are facing the same direction



# 8

1. Once servos are in place, with a screwdriver secure 3D foot model to servo.

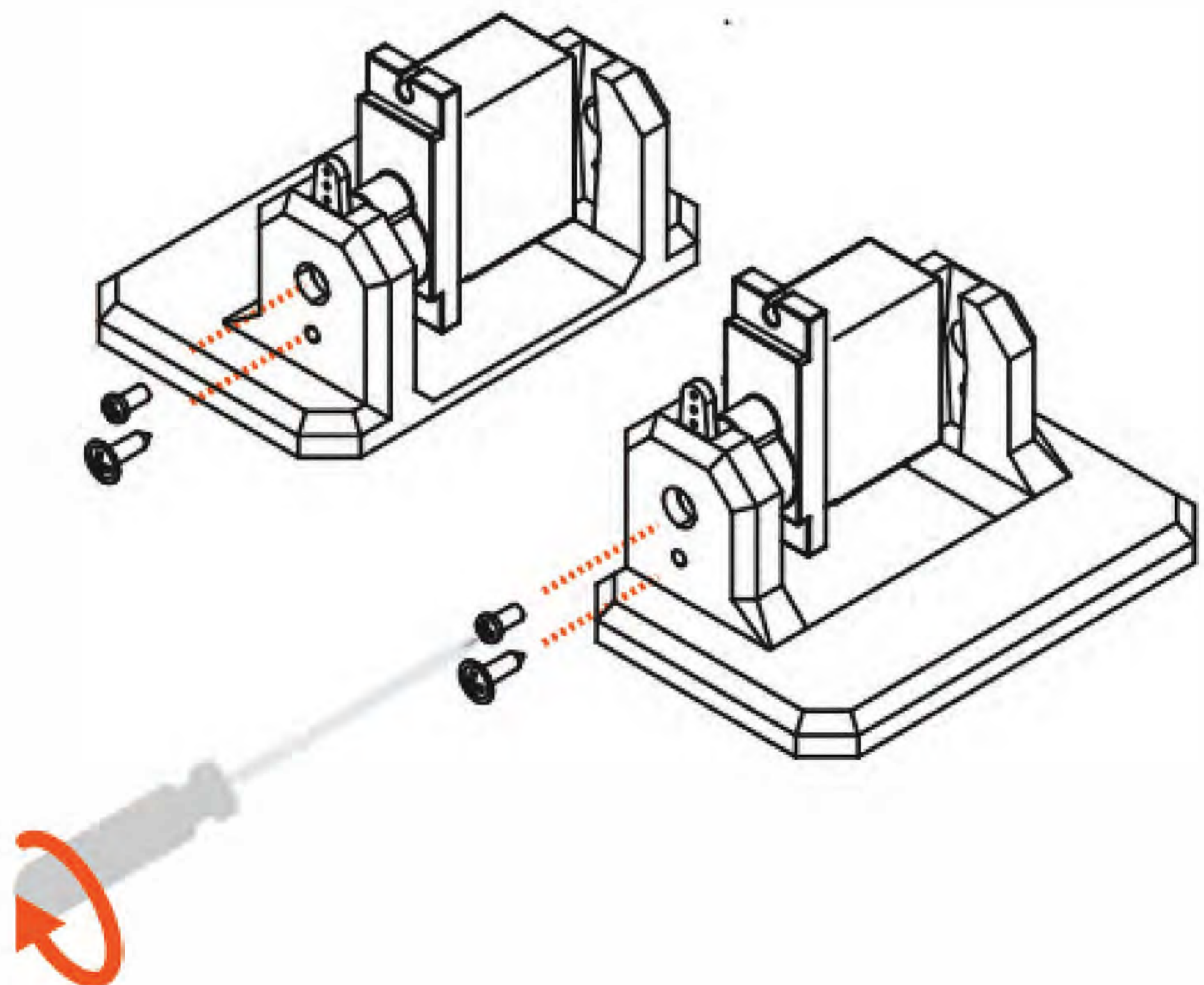



# 9

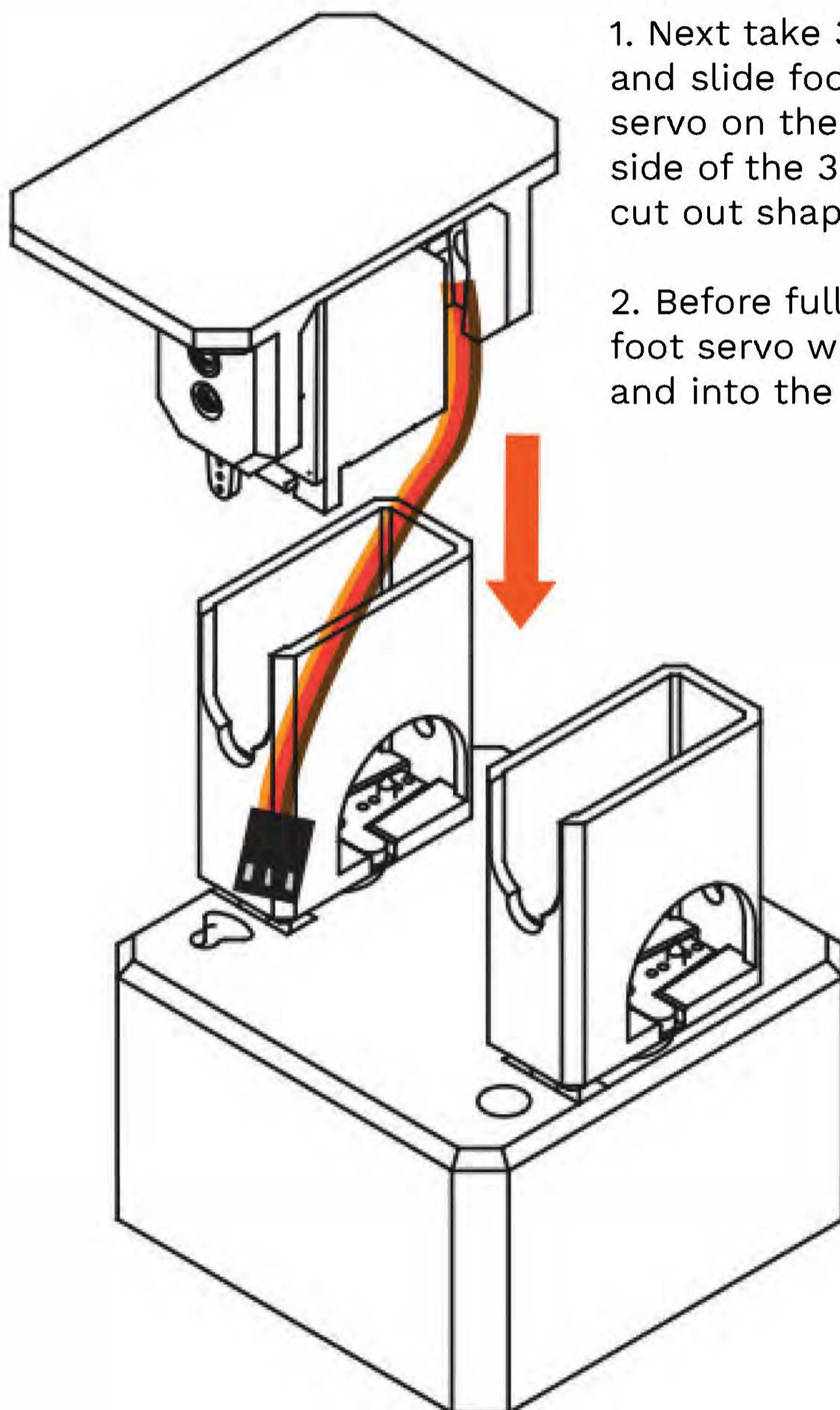

1. Next take 3D feet with servo and slide foot on so that the servo on the foot is facing the side of the 3D leg, that has the cut out shape of the servo.

2. Before fully inserting, feed the foot servo wire through the leg and into the body.



# 10

1. Do the same for the other side.

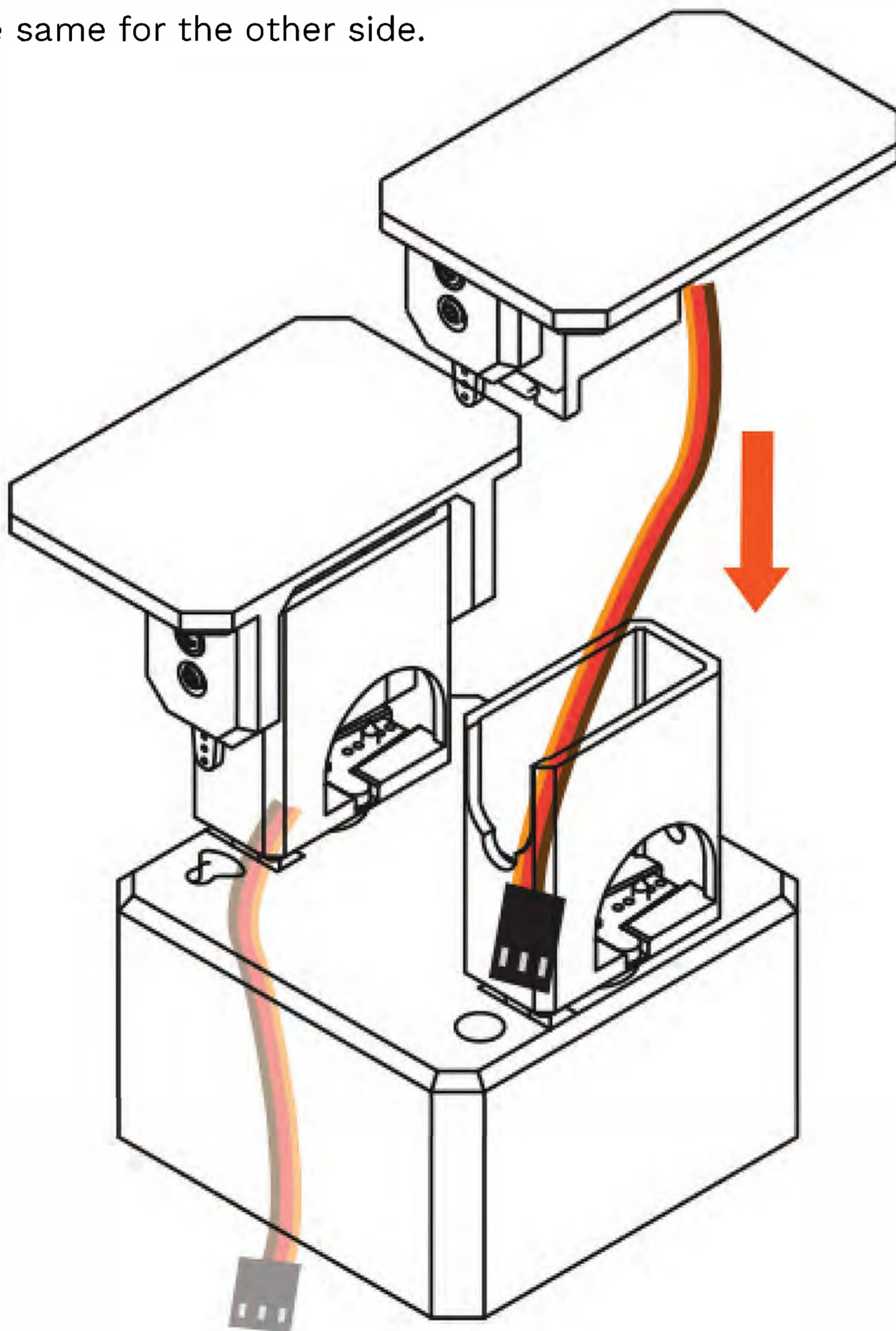



# 11

1. Pull wires fully through

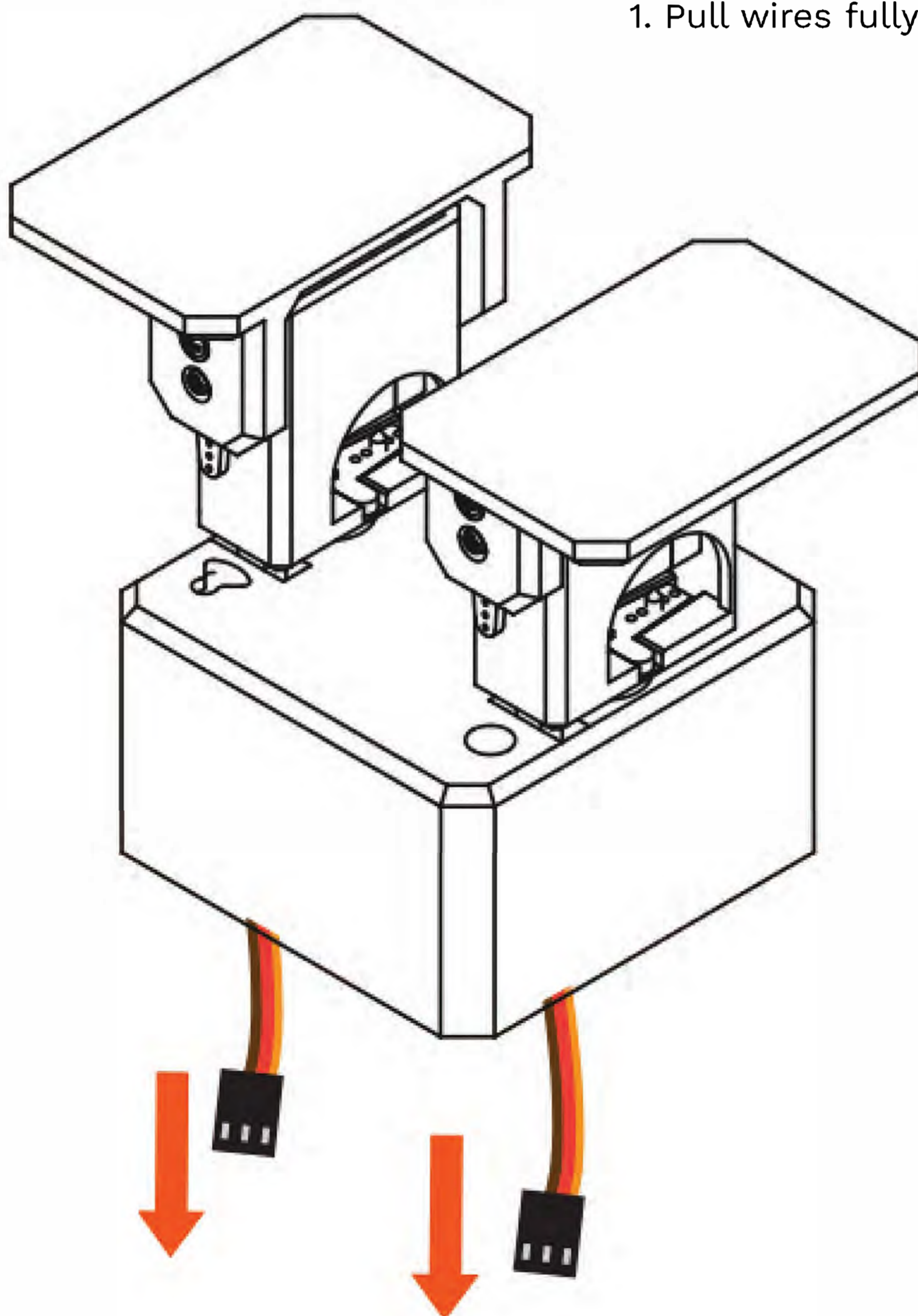



# 12

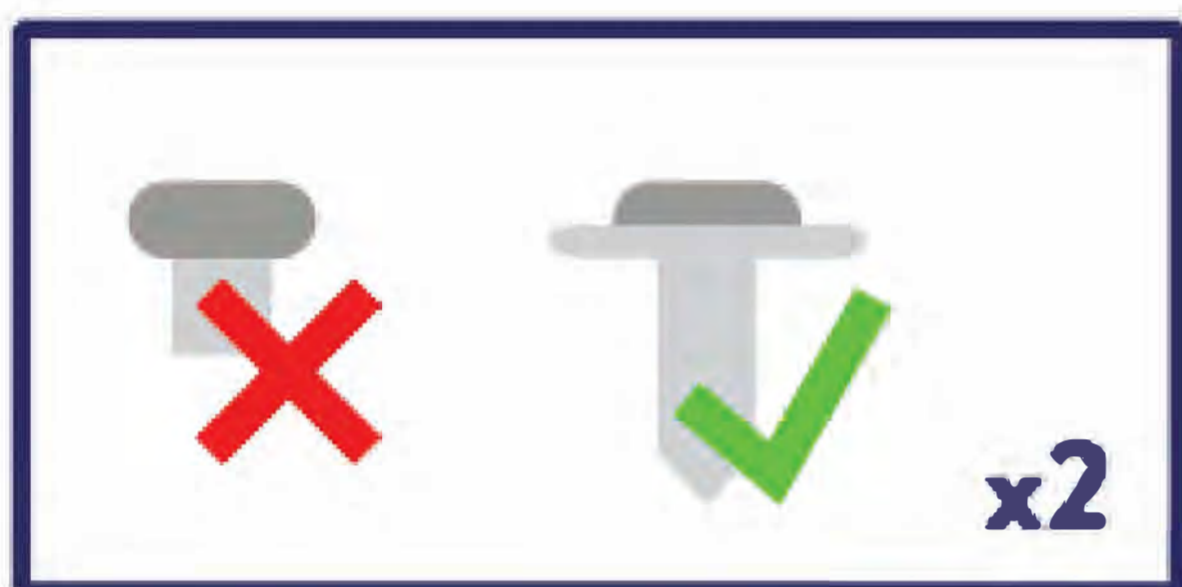

1. Carefully place screw inside leg (use pliers to assist if needed)

2. Slide screwdriver through the provide hole to all access to turn the screw into place

3. Screw should hold foot to leg of robot. This will prevent the foot from sliding off.

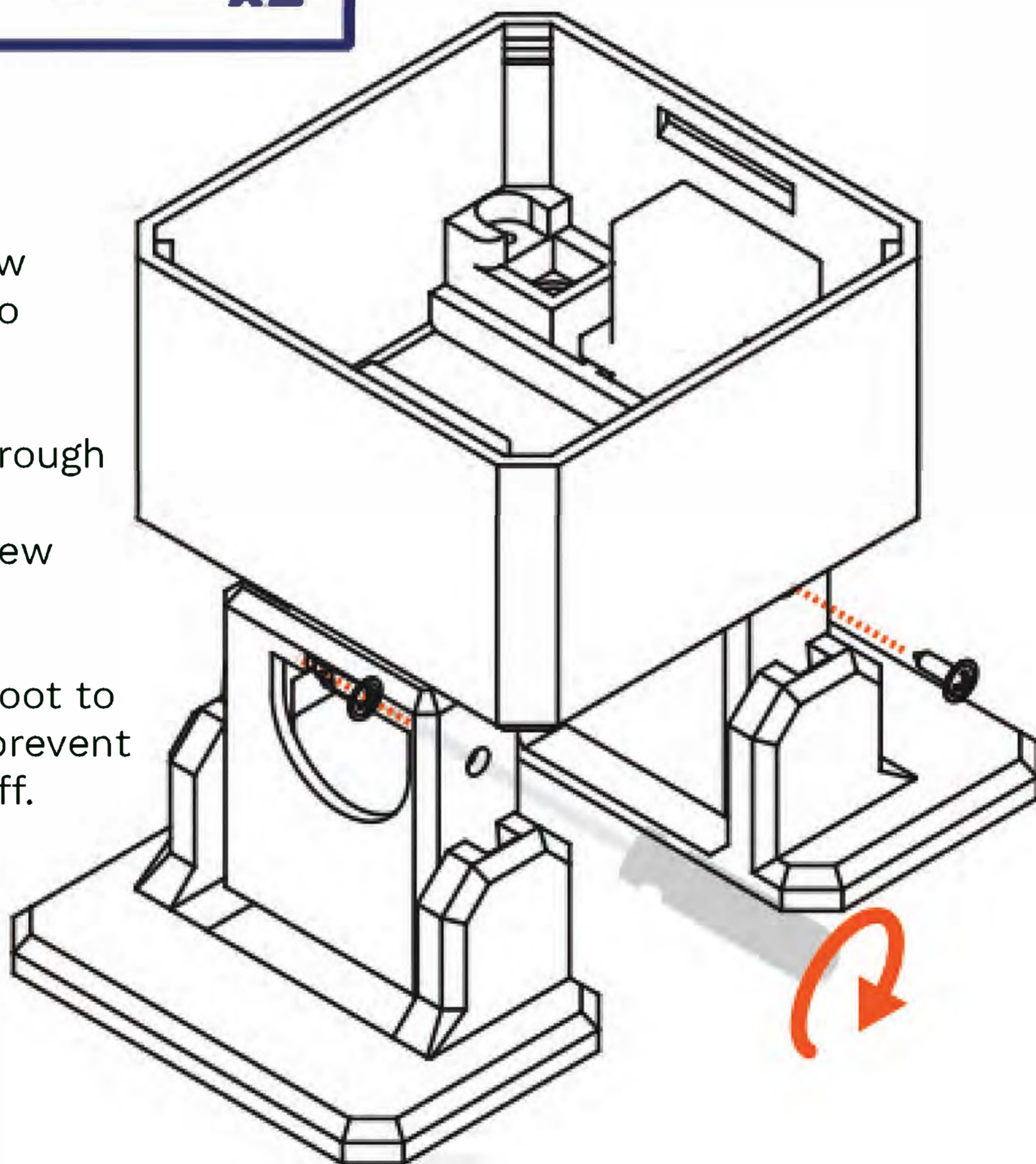



# 13

1. Place Arduino Nano onto Nano shield.
2. Make sure all pins of the Nano are fully inserted.

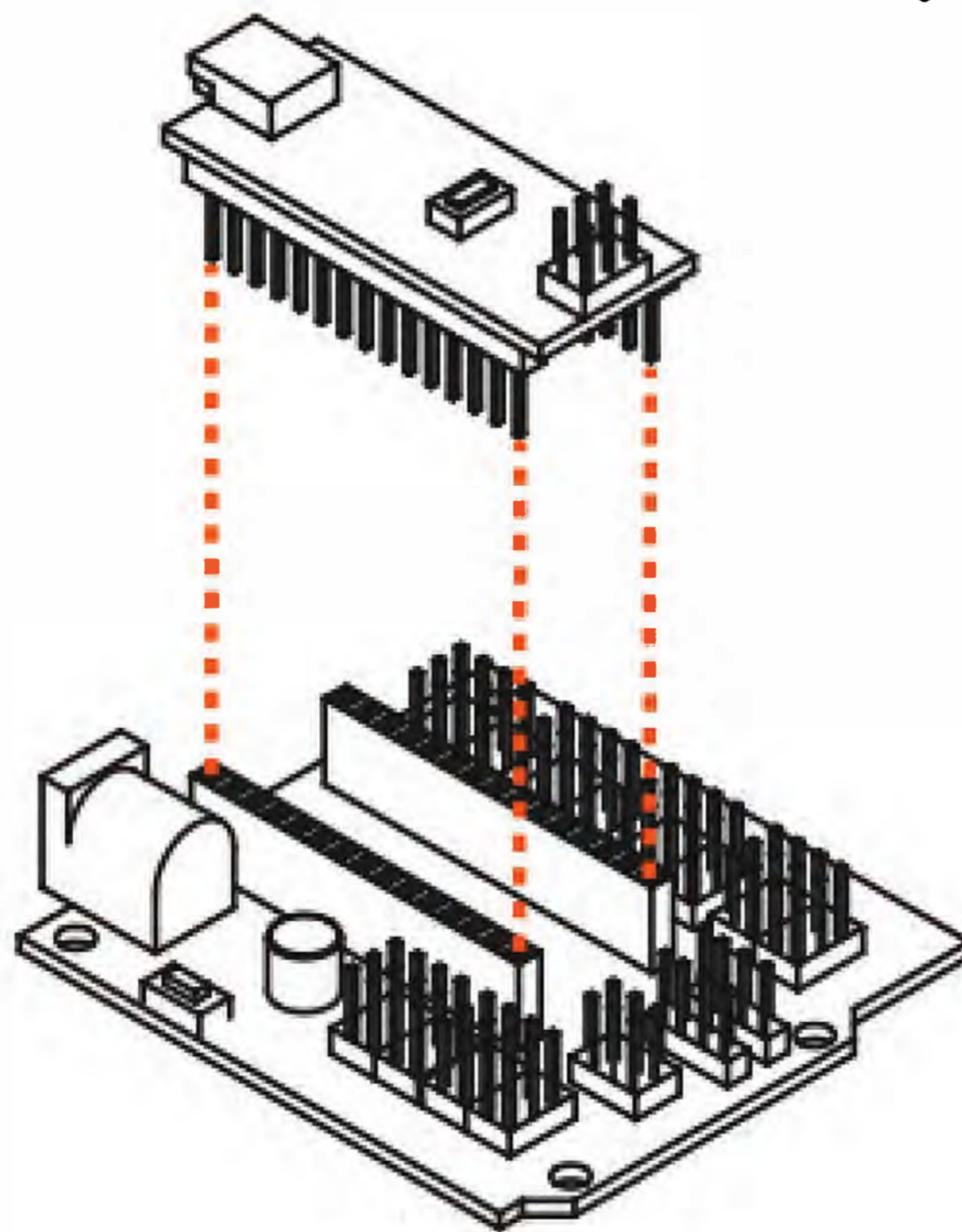



# 14

<https://wikifactory.com/+OttoDIY/eyes>

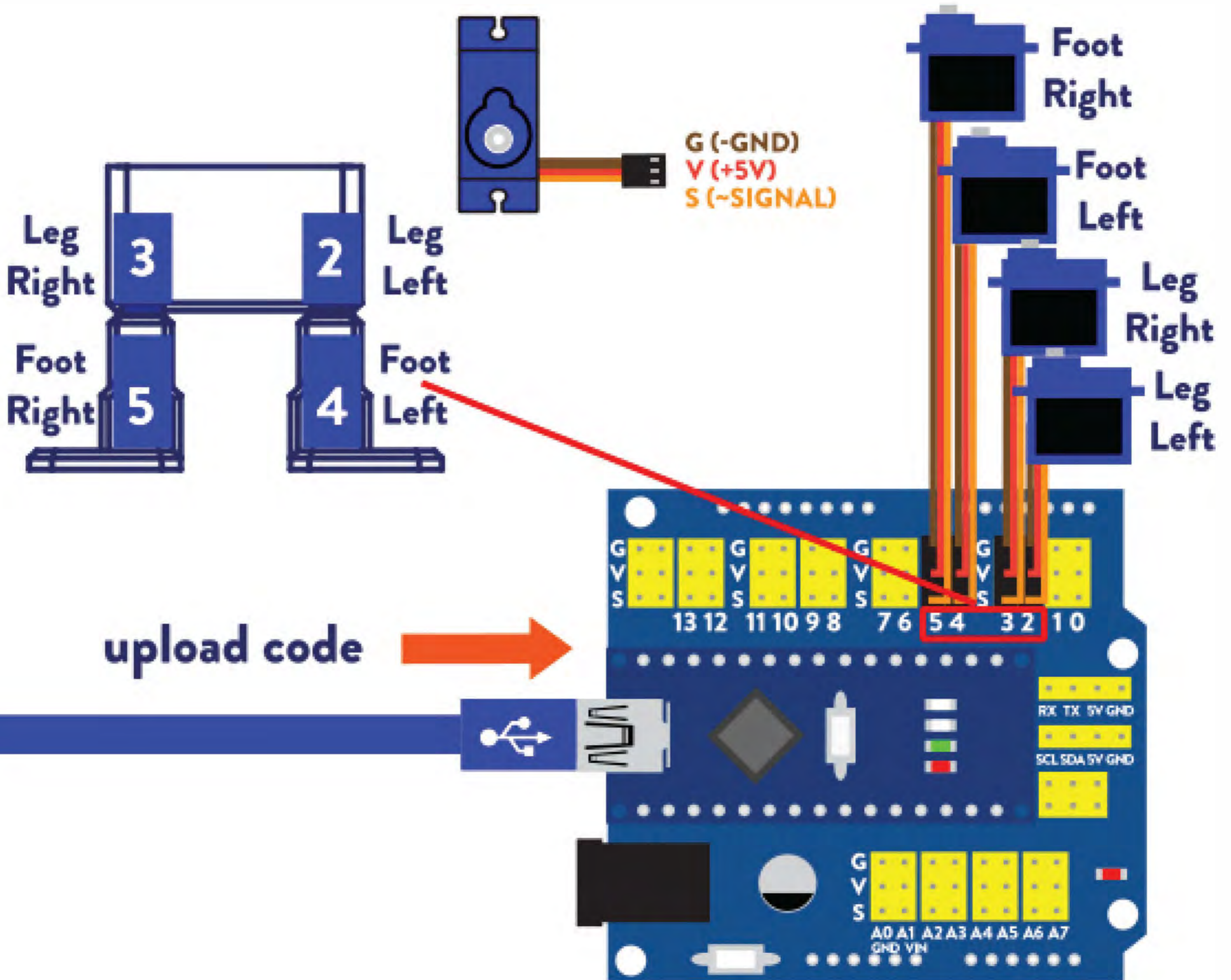



# 15

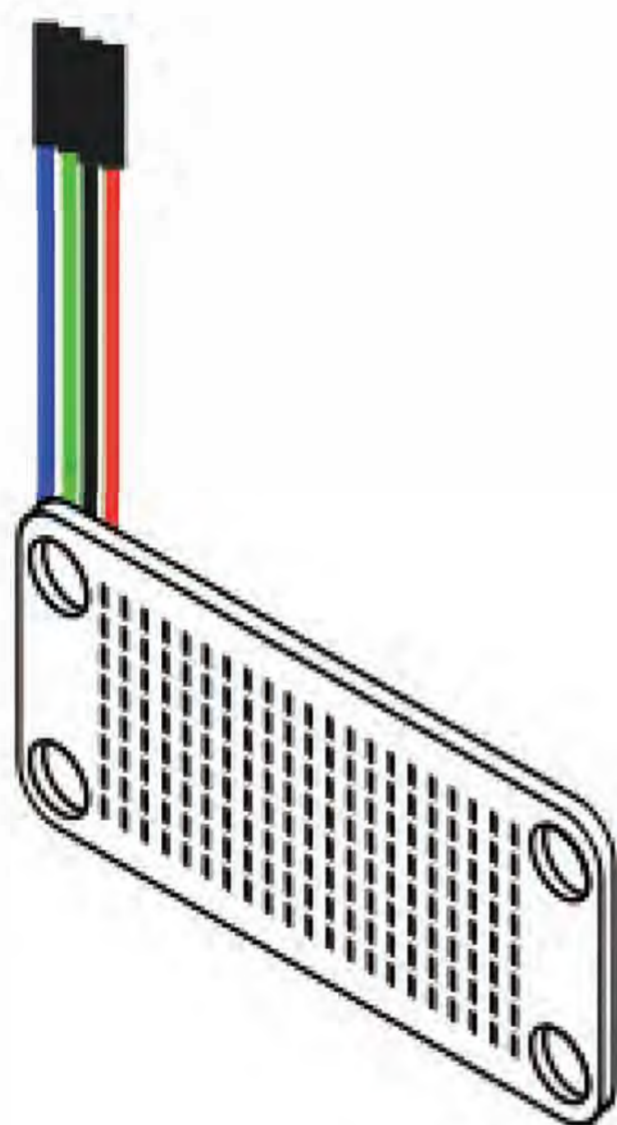

1. Place matrix LED into face 3D model.

2. Connect F-F wires to piezo buzzer

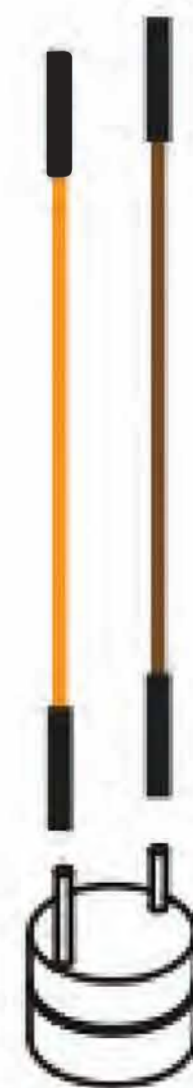
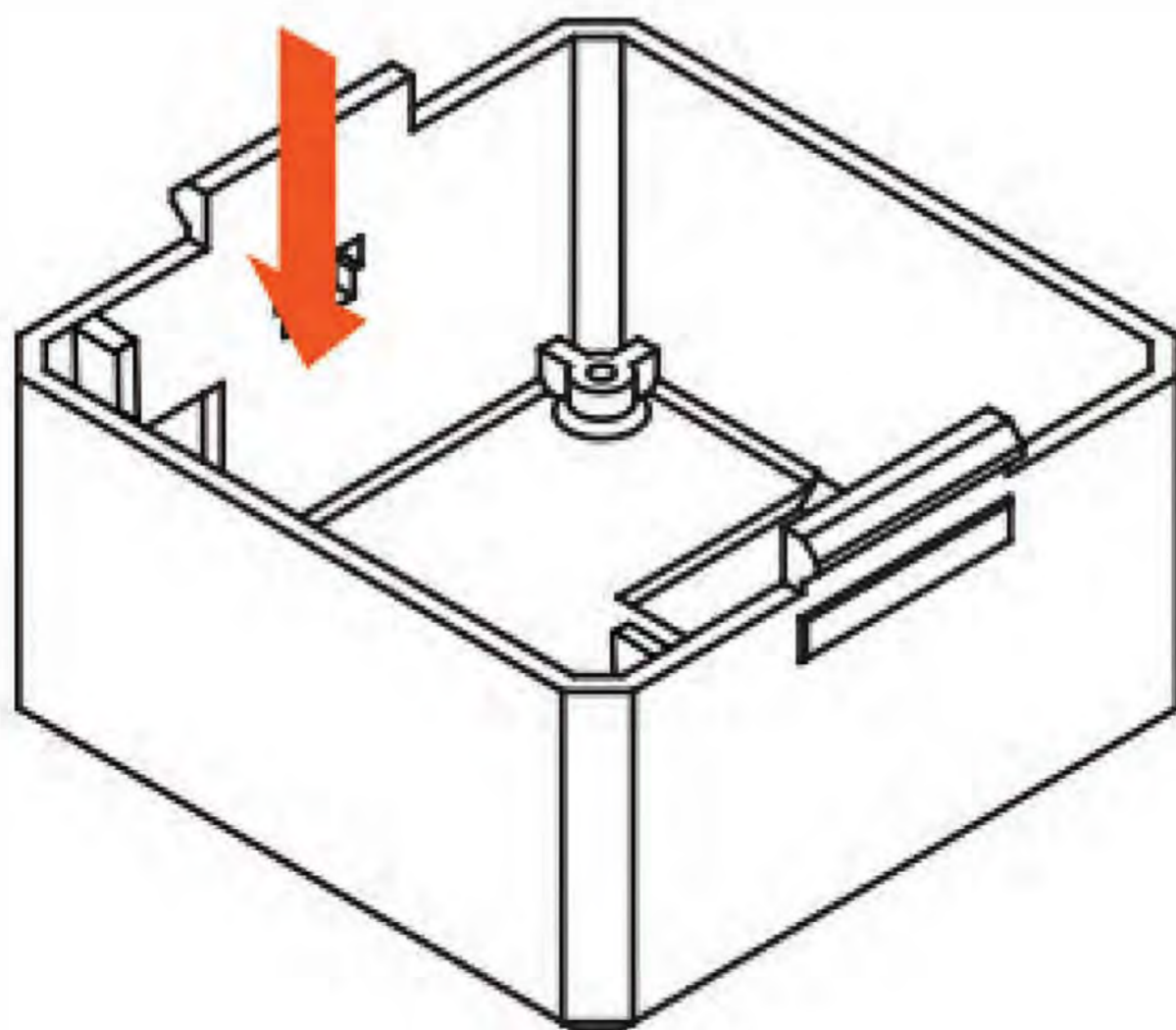



# 16

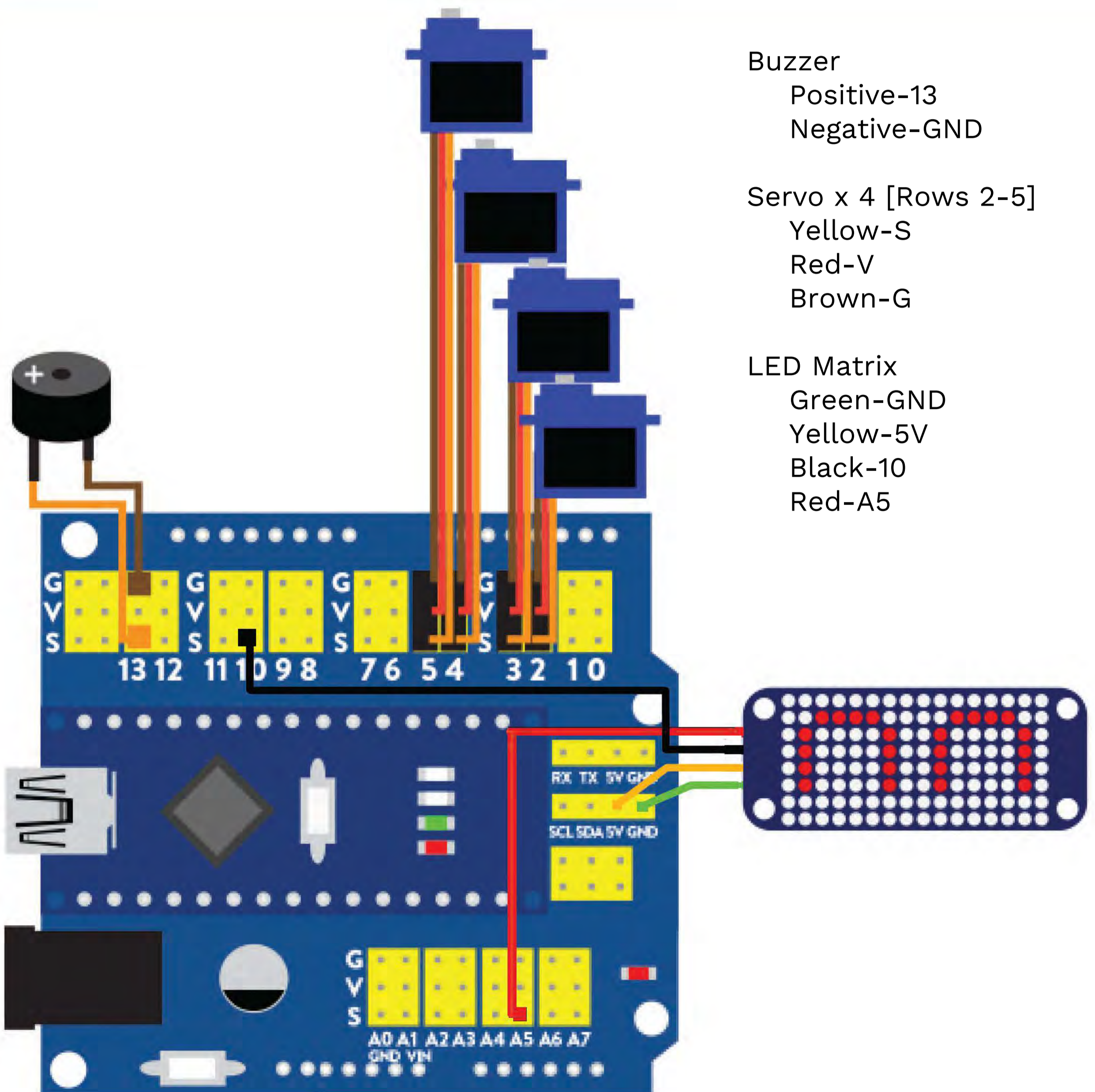



# 17

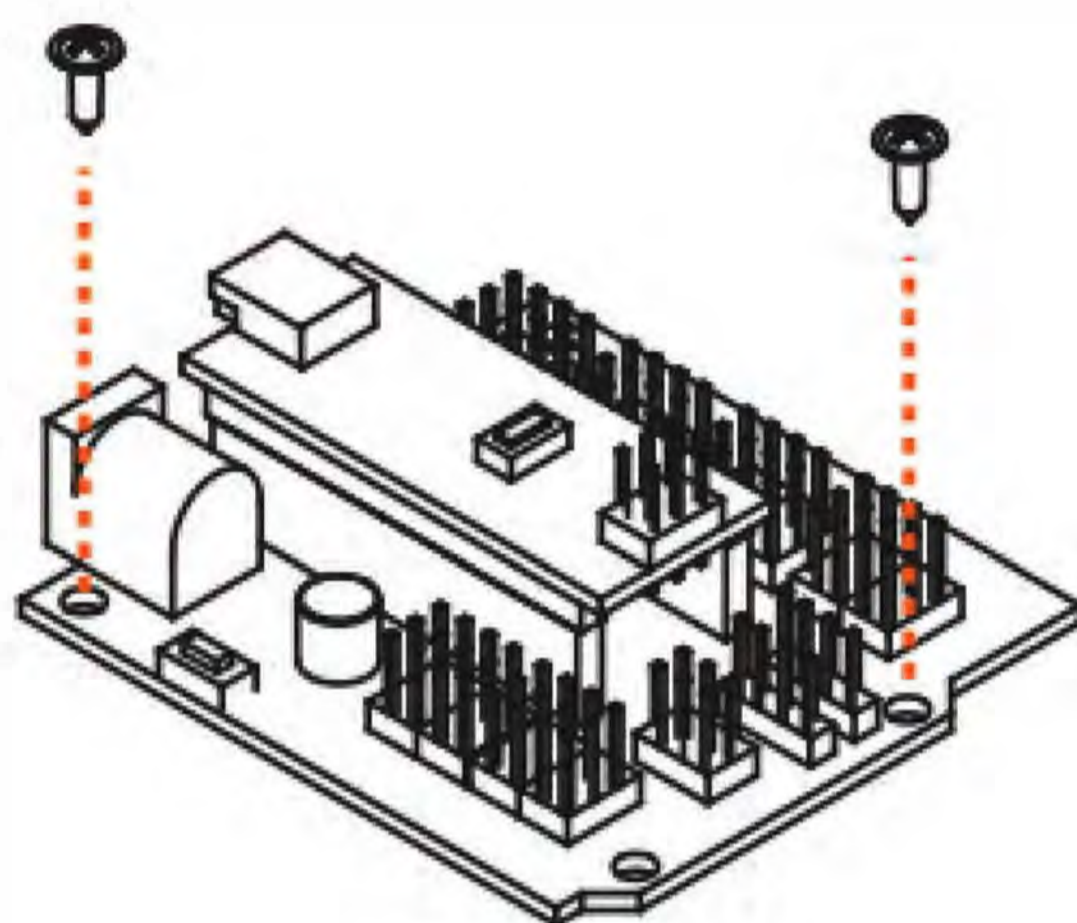

1. Place shield with Nano into 3D printed head.

2. Place shield so that usb port and power jack are accessible through the holes on the back of the 3D model.

3. Use at least two screws on opposite ends and across from each other to secure the board down.

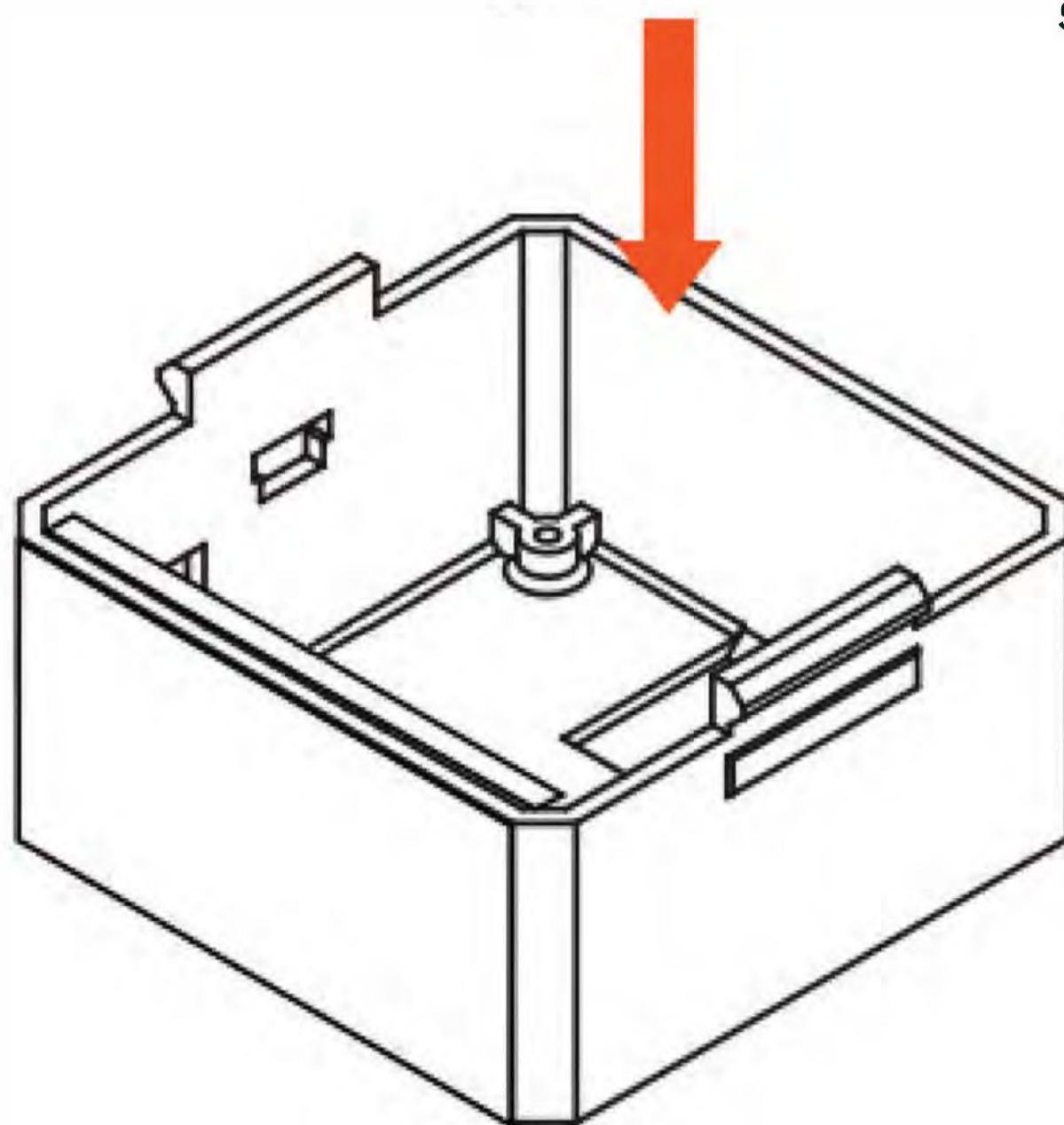



# 18

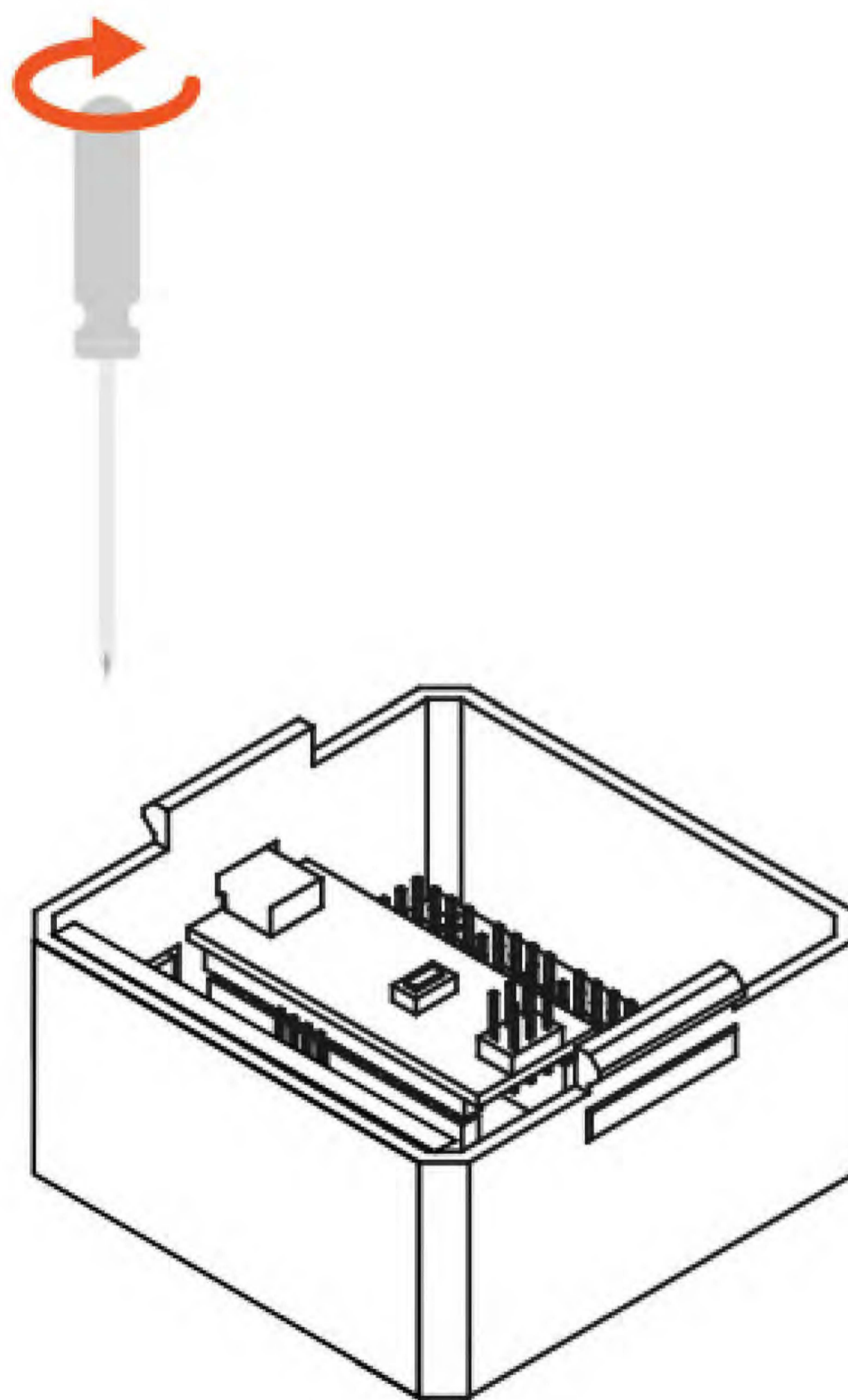



# 19

1. Place buzzer into designated housing inside of 3D model body

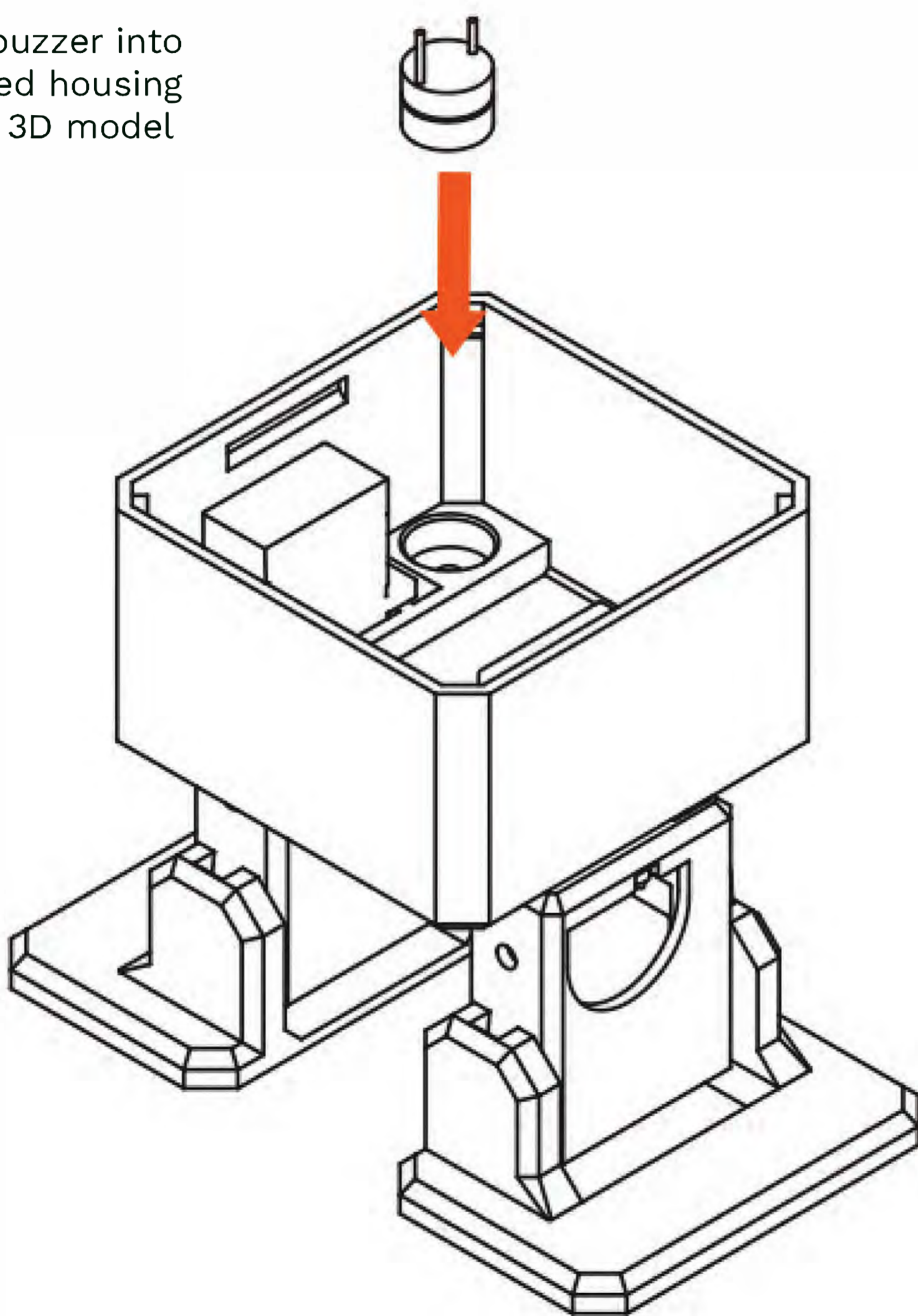



# 20

1. Last, place 3D head on 3D body and you are done!

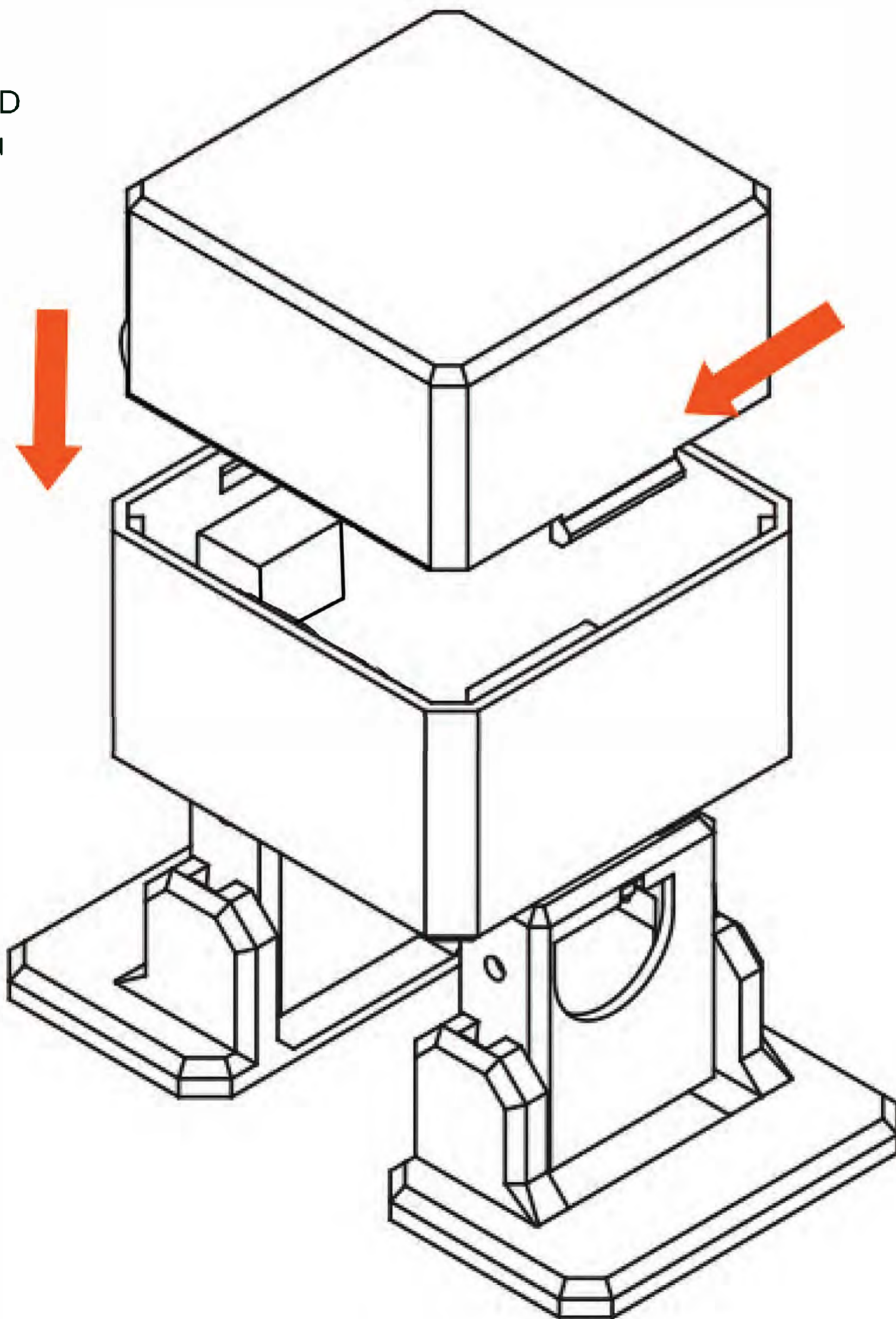



# 21

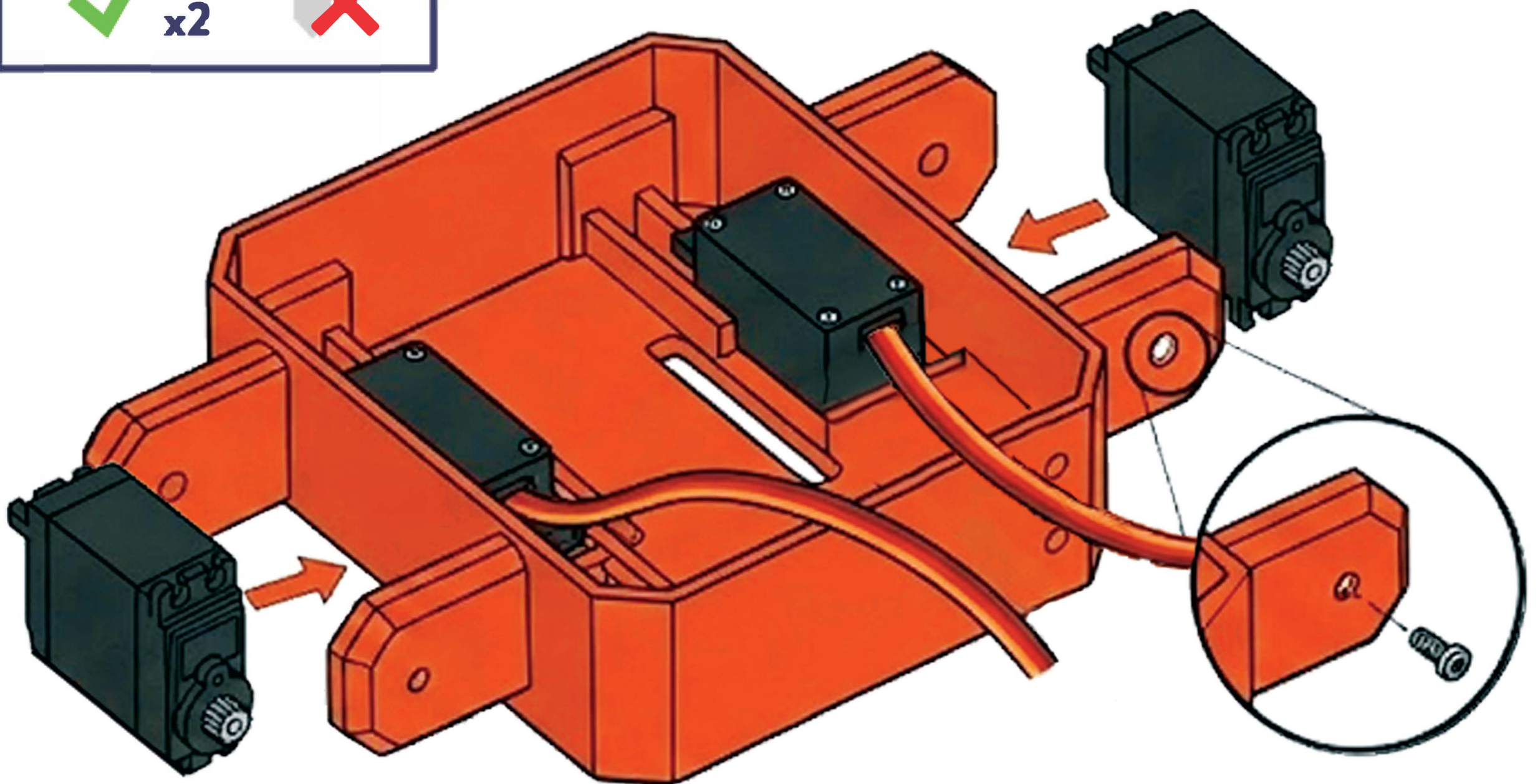
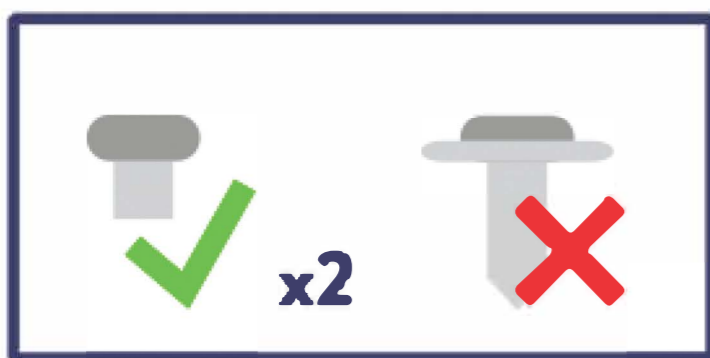

1. To add arms to robot slide servos into each side.
2. Slot servo gears into the provided hole.
3. Add screws into hole to secure them in place.
4. Feed wire into body of robot.



# 22

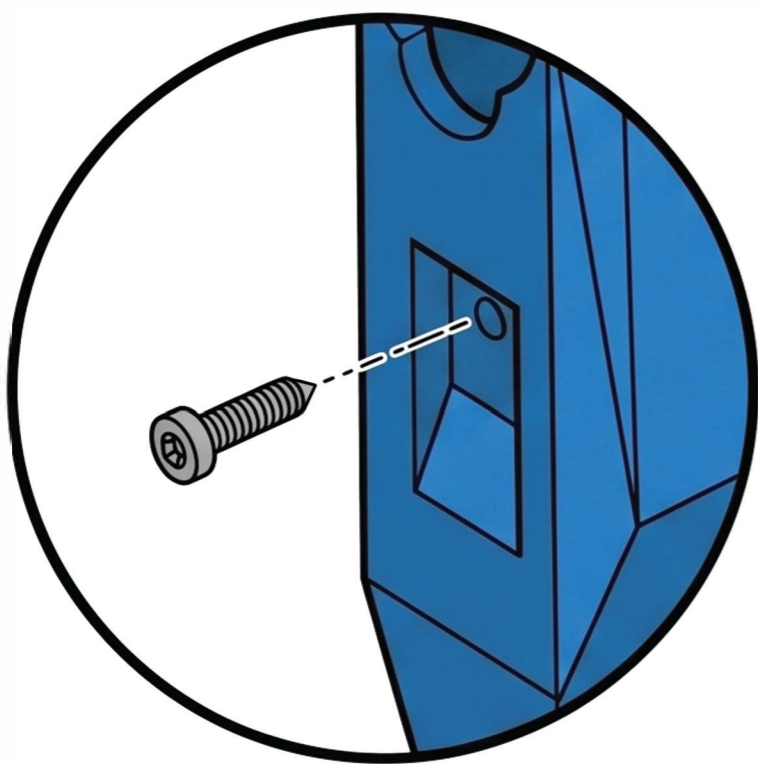
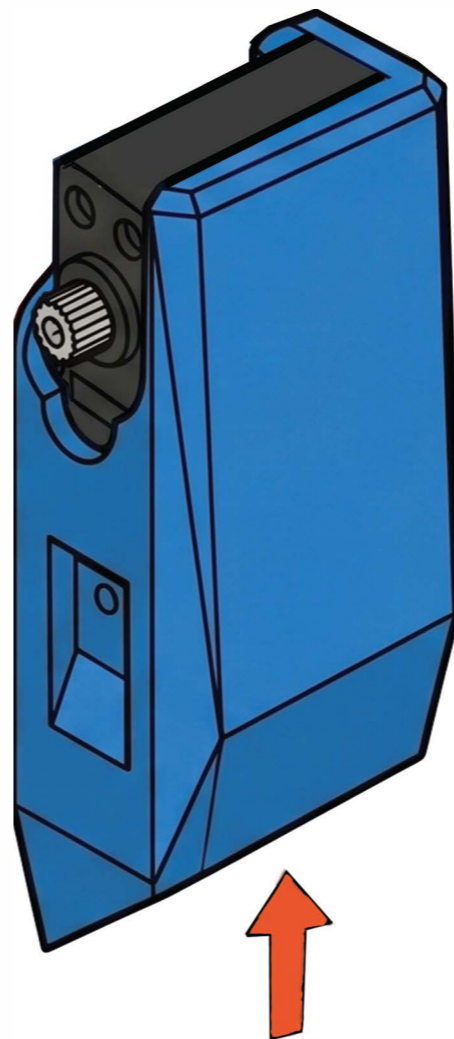

1. Slide 3D printed arm onto servo.
2. Make sure that arm is fully inserted.
3. Once secured in place take screw and secure 3D arm to the servo
4. Repeat for both arms.

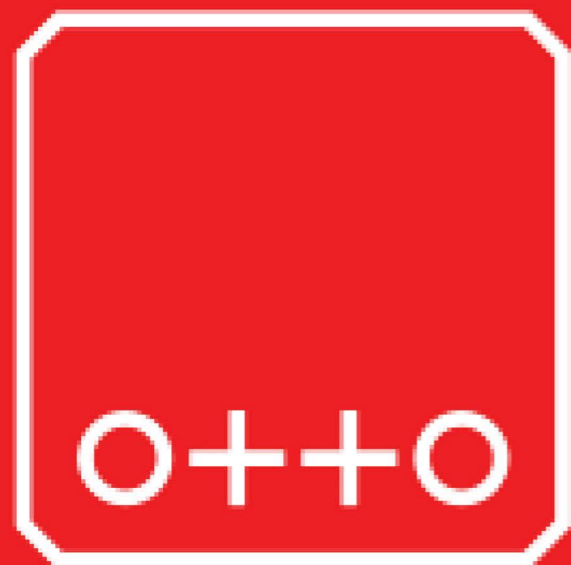

# 23

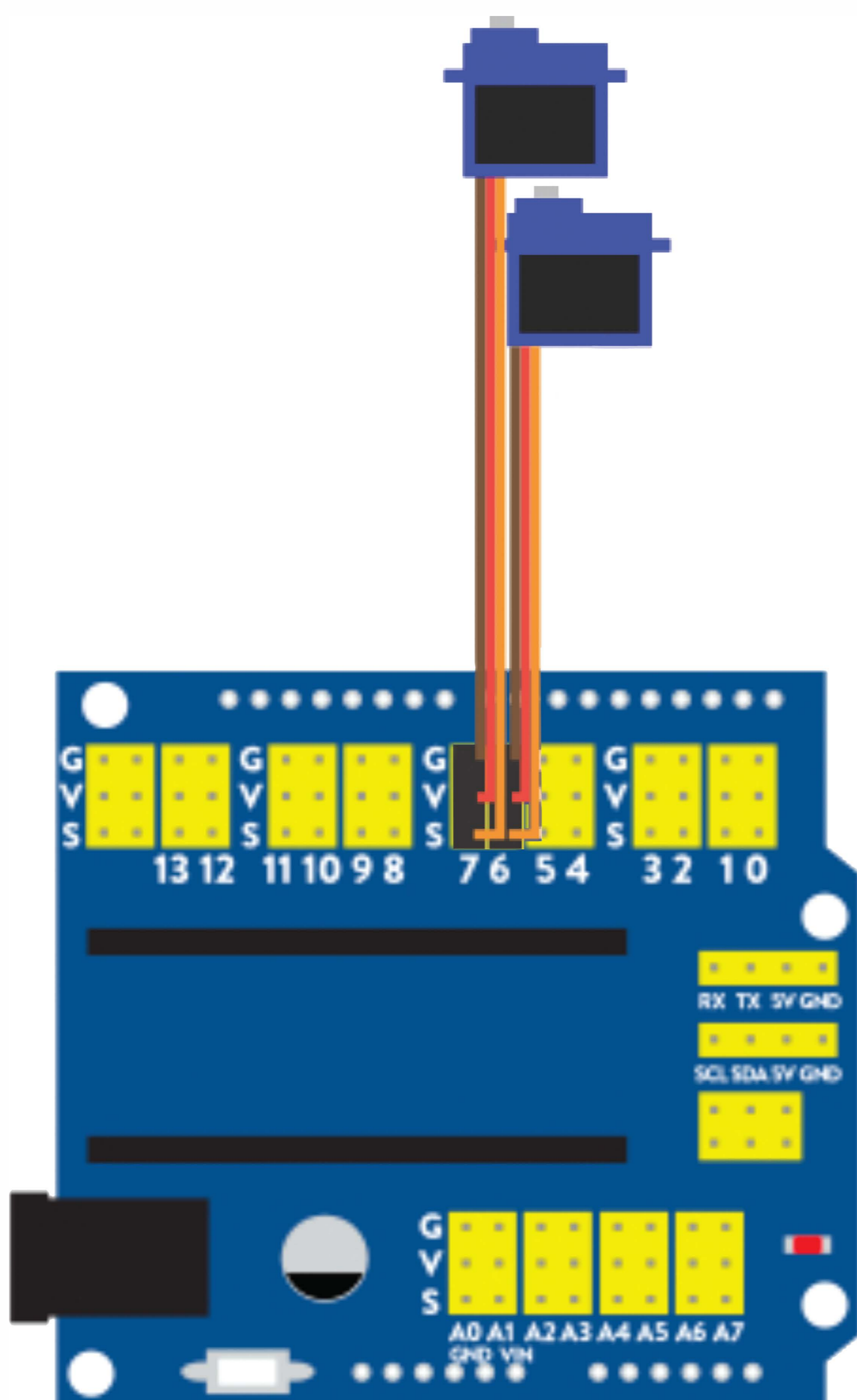

Left arm = pin 6  
S= Orange  
V= Red  
G= Brown

Right arm = pin 7  
S= Orange  
V= Red  
G= Brown